

**V6**

# **USER MANUAL**



**DIGITAL SOFTSTARTER**



# **V6**

———— *DIGITAL SOFT STARTER* ————

# User Manual

**Edition: August 2023**

Rev. B

# ABOUT THIS MANUAL

## DISCLAIMER

The examples and diagrams in this manual are included solely for illustrative purposes.

The information contained in this manual is subject to change at any time and without prior notice. In no event will responsibility or liability be accepted for direct, indirect or consequential damages resulting from the use or application of this equipment.

## POWER ELECTRONICS CONTACT INFORMATION

Power Electronics USA Inc.  
1510 N. Hobson Street, Gilbert,  
Phoenix  
AZ 85233  
UNITED STATES OF AMERICA  
US Sales: 602-354-4890 / (480) 519-  
5977

Power Electronics España, S.L.  
Polígono Industrial Carrases  
Ronda del Camp d'Aviació nº 4  
46160, Llíria (Valencia)  
SPAIN  
Telephone: (+34) 96 136 65 57  
Website: [www.power-electronics.com](http://www.power-electronics.com)

**REVISIONS CONTROL**

---

<b>DATE</b>	<b>REVISION</b>	<b>DESCRIPTION</b>
01/06/2023	A	First edition.
01/08/2023	B	Second edition.

---

**EN**

---

The equipment and technical documentation are periodically updated. Power Electronics reserves the right to modify all or part of the contents of this manual without previous notice. To consult the most updated information of this product, you may access our website [www.power-electronics.com](http://www.power-electronics.com), where the latest version of this manual can be downloaded. The reproduction or distribution of the present manual is strictly forbidden, unless express authorization from Power Electronics.



# SAFETY SYMBOLS

Always follow safety instructions to prevent accidents and potential hazards from occurring.

In this manual, safety messages are classified as follows:



## WARNING

Indicates a hazard that may cause personal injury or death.



## CAUTION

Indicates a hazard that may damage the equipment or installation.



## NOTICE

Provides helpful information.

Other symbols used in this manual for safety messages are the following:



Hot surface. Be careful and follow the instructions to avoid burns and personal injuries.



Risk of fire. Be careful and follow the instructions to prevent causing an unintentional fire.



Caution, risk of electric shock. Energy storage timed discharge. Wait for the indicated time to avoid electrical hazards.



Caution, risk of hearing damage. Wear hearing protection.

---

# Table of contents

<b>1 Caution statements</b> .....	<b>9</b>
Electrical shock risk .....	9
Unexpected operation.....	10
<b>2 System design</b> .....	<b>11</b>
Feature list .....	11
Model code .....	12
Model selection .....	12
Current ratings .....	12
Dimensions and weights .....	15
Physical installation.....	16
Accessories.....	16
Main contactor or circuit breaker.....	18
Power factor correction .....	18
Short circuit protection devices (SCPD).....	19
IEC coordination with short circuit protection devices.....	19
Standard fault short circuit .....	20
High fault short circuit .....	21
Specifications.....	26
Disposal instructions .....	27
<b>3 Installation</b> .....	<b>28</b>
Command source.....	28
Setup procedure overview .....	28
Inputs	29
Outputs .....	31
Control voltage.....	33
Motor connection .....	35
Earth terminations.....	36
Typical installation.....	36
Quick setup .....	38
<b>4 Setup tools</b> .....	<b>39</b>
Set date and time.....	39
Command source.....	39



Commissioning .....	39
Run simulation .....	40
Load/save settings .....	41
USB save and load .....	41
Auto-start/stop.....	42
Network address .....	43
Digital I/O state .....	44
Analog I/O state .....	44
Serial number and rating.....	44
Software versions .....	45
Thermistor reset.....	45
Reset thermal model.....	45
<b>5 Logs .....</b>	<b>46</b>
Event log .....	46
Counters .....	46
QR code.....	46
<b>6 Keypad and feedback .....</b>	<b>48</b>
The keypad .....	48
Remote keypad.....	49
Lighten/darken the display .....	49
Starter status LEDs.....	49
Displays .....	50
<b>7 Operation .....</b>	<b>53</b>
Start, stop and reset commands .....	53
Command override .....	53
Auto-start/stop.....	53
PowerThrough .....	54
Emergency mode.....	55
Auxiliary trip .....	55
Typical control methods .....	56
Stop methods.....	61
Pump clean .....	65
Reverse direction operation .....	65
Jog operation .....	67
Inside delta operation.....	67
Secondary motor set.....	68
<b>8 Programmable parameters .....</b>	<b>69</b>
Main menu .....	69

Altering parameter values .....	69
Adjustment lock.....	69
Parameter list.....	70
1 Motor Details.....	77
2 Motor Start/Stop.....	78
3 Motor Start/Stop-2.....	81
4 Auto-Start/Stop .....	84
5 Protection Levels .....	87
6 Protection Action.....	89
7 Inputs .....	94
8 Relay Outputs .....	96
9 Analog Output.....	99
10 Display .....	100
11 Pump Clean .....	103
12 Communications Card .....	104
20 Advanced.....	107
30 Smart Card Parameters.....	109
40 Ground Fault.....	109
41 Calibrate 4-20 mA.....	110
<b>9 Troubleshooting.....</b>	<b>111</b>
Protection responses .....	111
Trip messages .....	111
General faults.....	119

# 1 CAUTION STATEMENTS

1

Caution statements cannot cover every potential cause of equipment damage but can highlight common causes of damage. It is the installer's responsibility to read and understand all instructions in this manual prior to installing, operating or maintaining the equipment, to follow good electrical practice including applying appropriate personal protective equipment and to seek advice before operating this equipment in a manner other than as described in this manual.



## NOTICE

The soft starter is not user serviceable. The unit should only be serviced by authorised service personnel. **Unauthorised tampering with the unit will void the product warranty.**



## FOR YOUR SAFETY

- The STOP function of the soft starter does not isolate dangerous voltages from the output of the starter. The soft starter must be disconnected by an approved electrical isolation device before accessing electrical connections.
- Soft starter protection features apply to motor protection only. It is the user's responsibility to ensure safety of personnel operating machinery.
- The soft starter is a component designed for integration within an electrical system; it is therefore the responsibility of the system designer/user to ensure the system is safe and designed to comply with relevant local safety standards.

## Electrical shock risk



### WARNING – ELECTRICAL SHOCK HAZARD

The voltages present in the following locations can cause severe electric shock and may be lethal:

- AC supply cables and connections
- Output cables and connections
- Many internal parts of the starter

EN

**SHORT CIRCUIT**

The soft starter is not short circuit proof. After severe overload or short circuit, the operation of the soft starter should be fully tested by an authorised service agent.

**GROUNDING AND BRANCH CIRCUIT PROTECTION**

It is the responsibility of the user or person installing the soft starter to provide proper grounding and branch circuit protection according to local electrical safety codes.

**Unexpected operation****WARNING – ACCIDENTAL STARTS**

In some installations, accidental starts may pose an increased risk to safety of personnel or damage to the machines being driven. In such cases, it is recommended that the power supply to the soft starter is fitted with an isolating switch and a circuit-breaking device (eg power contactor) controllable through an external safety system (eg emergency stop, fault detector).

**WARNING – STARTER MAY START OR STOP UNEXPECTEDLY**

The soft starter will respond to control commands from various sources, and could start or stop unexpectedly. Always disconnect the soft starter from mains voltage before accessing the starter or load.

**WARNING – DISCONNECT MAINS BEFORE ACCESSING STARTER OR LOAD**

The soft starter has built-in protections which can trip the starter in the event of faults and thus stop the motor. Voltage fluctuations, power cuts and motor jams may also cause the motor to trip.

The motor could restart after the causes of shutdown are rectified, which may be dangerous for personnel. Always disconnect the soft starter from mains voltage before accessing the starter or load.

**CAUTION – MECHANICAL DAMAGE FROM UNEXPECTED RESTART**

The motor could restart after the causes of shutdown are rectified, which may be dangerous for certain machines or installations. In such cases, it is essential that appropriate arrangements are made against restarting after unscheduled stops of the motor.

## 2 SYSTEM DESIGN

# 2

EN

### Feature list

#### Streamlined setup process

- Configuration profiles for common applications
- Built-in metering and inputs/outputs

#### Easy to understand interface

- Multi-language menus and displays
- Descriptive option names and feedback messages
- Real-time performance graphs

#### Supports energy efficiency

- IE3 compatible
- 99% energy efficient when running
- Soft start technology avoids harmonic distortion

#### Extensive range of models

- 24 A~1250 A (nominal)
- 200~525 VAC
- 380~690 VAC
- Bypassed or continuous options
- In-line or inside delta connection

#### Extensive input and output options

- Remote control inputs (2 x fixed, 2 x programmable)
- Relay outputs (2 x fixed, 2 x programmable)
- Analog output

#### Versatile starting and stopping options

- Scheduled start/stop
- Adaptive Control
- Constant Current
- Current Ramp
- Pump Clean
- Timed voltage ramp soft stop
- Coast To Stop
- DC Brake
- Soft Brake
- Reverse Direction

#### Customisable protection

- Motor overload
- Excess Start Time
- Undercurrent/Overcurrent
- Underpower/Overpower
- Undervoltage/Overvoltage
- Current imbalance
- Input Trip
- Motor thermistor

#### Optional features for advanced applications

- Smart cards
- Communication options: DeviceNet, Ethernet/IP, Modbus RTU, Modbus TCP, Profibus, Profinet
- Ground fault protection

## Model code

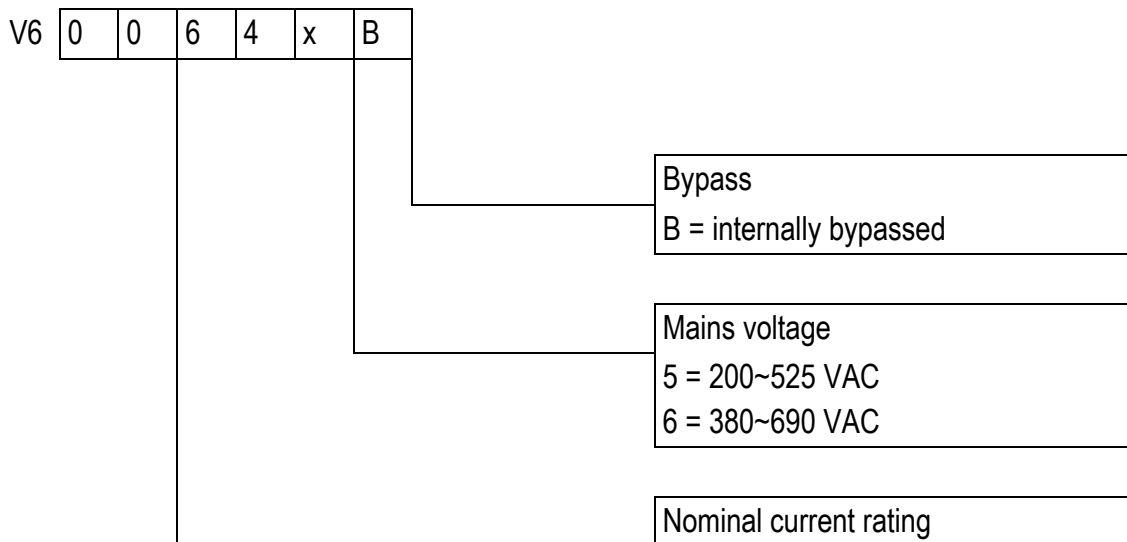

## Model selection

### Starter sizing

The soft starter must be the correct size for the motor and the application.

Select a soft starter that has a current rating at least equal to the motor's full load current (nameplate) rating, at the start duty.

The soft starter's current rating determines the maximum motor size it can be used with. The rating depends on the number of starts per hour, the length and current level of the start, and the amount of time the soft starter will be off (not passing current) between starts.

The soft starter's current rating is only valid when used in the conditions specified in the AC53 code. The current rating may be higher or lower in different operating conditions.

### AC53b format (bypassed current rating)

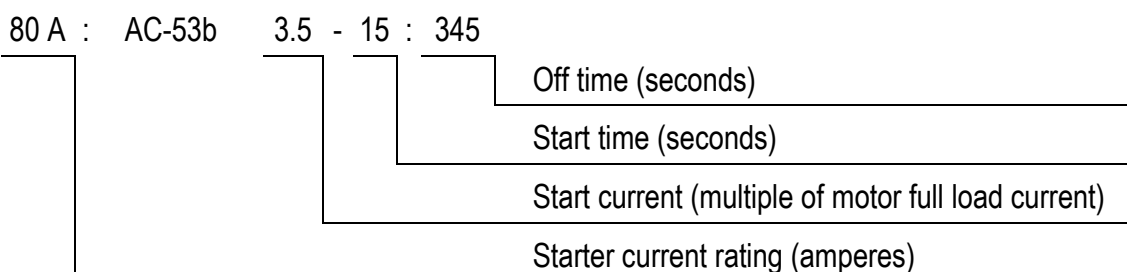

## Current ratings

Contact your local supplier for ratings under operating conditions not covered by these ratings charts.

### IEC ratings

All ratings are calculated at altitude of 1000 metres and ambient temperature of 40 °C.

#### • In-line installation, bypassed

	3.0-10:350	3.5-15:345	4.0-10:350	4.0-20:340	5.0-5:355
V60024xB	24	20	19	16	16
V60042xB	42	34	34	27	31
V60052xB	52	41	39	34	34
	3.0-10:590	3.5-15:585	4.0-10:590	4.0-20:580	5.0-5:595
V60064xB	64	62	60	50	53
V60105xB	105	86	84	68	76
V60115xB	115	107	104	86	95
V60135xB	135	129	126	103	115
V60200xB	200	170	165	138	150
V60229xB	229	194	187	157	170
V60250xB	250	244	230	200	202
V60352xB	352	285	277	234	257
V60410xB	410	410	410	379	400
V60550xB	550	526	505	427	462
V60835xB	835	654	630	535	592
V61070xB	1070	950	905	785	834
V61230xB	1230	1154	1090	959	989
V61250xB	1250	1250	1250	1155	1250

#### • Inside delta installation, bypassed

	3.0-10:350	3.5-15:345	4.0-10:350	4.0-20:340	5.0-5:355
V60024xB	36	30	29	24	24
V60042xB	63	51	51	41	47
V60052xB	78	62	59	51	51
	3.0-10:590	3.5-15:585	4.0-10:590	4.0-20:580	5.0-5:595
V60064xB	96	93	90	75	80
V60105xB	158	129	126	102	114
V60115xB	173	161	156	129	143
V60135xB	203	194	189	155	173
V60200xB	300	255	248	207	225
V60229xB	344	291	281	236	255
V60250xB	375	366	345	300	303

	3.0-10:590	3.5-15:585	4.0-10:590	4.0-20:580	5.0-5:595
V60352xB	528	428	415	351	386
V60410xB	615	615	615	568	600
V60550xB	825	789	758	640	694
V60835xB	1253	981	945	803	888
V61070xB	1605	1425	1358	1178	1251
V61230xB	1845	1731	1635	1439	1484
V61250xB	1875	1875	1875	1733	1875

### NEMA motor ratings

All ratings are calculated at altitude of 1000 metres and ambient temperature of 50 °C.

- In-line installation, bypassed**

	Normal 350%, 30 s, 4 starts per hour				Heavy 450%, 30 s, 4 starts per hour			
	A	HP @240 VAC	HP @480 VAC	HP @600 VAC	A	HP @240 VAC	HP @480 VAC	HP @600 VAC
V60024xB	17	5	10	15	14	3	10	10
V60042xB	28	10	20	25	22	7.5	15	20
V60052xB	35	10	25	30	28	10	20	25
V60064xB	52	15	40	40	40	10	25	30
V60105xB	77	25	60	60	52	15	40	50
V60115xB	81	30	60	75	65	20	50	60
V60135xB	99	30	75	100	77	25	60	75
V60200xB	131	50	100	125	104	40	75	100
V60229xB	156	60	125	150	124	40	100	100
V60250xB	195	75	150	200	156	60	125	150
V60352xB	240	75	200	200	180	60	150	150
V60410xB	377	150	300	350	302	100	250	300
V60550xB	414	150	350	450	321	125	250	300
V60835xB	515	200	450	500	414	150	350	450
V61070xB	797	300	600	800	620	250	500	600
V61230xB	985	400	800	1000	768	300	600	800
V61250xB	1180	500	900	1200	904	350	700	900



### Dimensions and weights

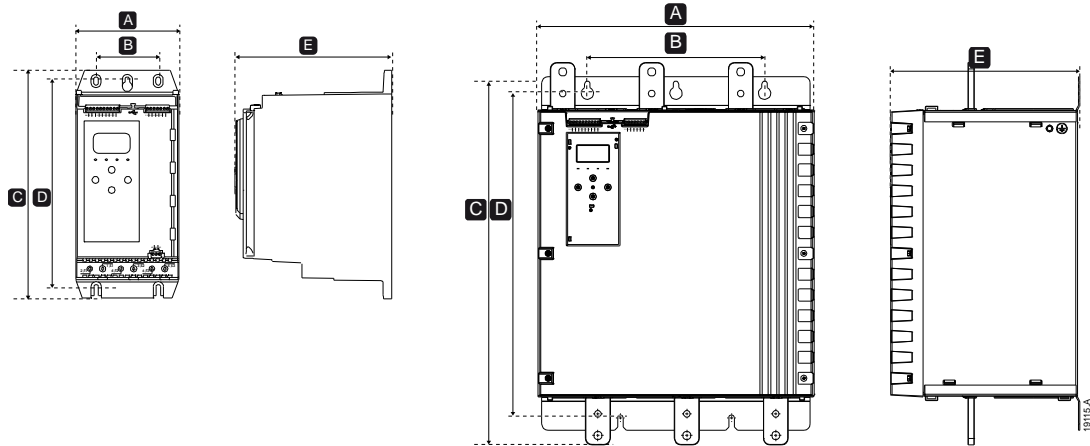

	Width mm (inch)		Height mm (inch)		Depth mm (inch)	Weight kg (lb)
	A	B	C	D		
V60024xB						4.8
V60042xB						(10.7)
V60052xB						4.9
V60064xB	152	92	336	307	233	(10.9)
V60105xB	(6.0)	(3.6)	(13.2)	(12.1)	(9.2)	5.5
V60115xB						(12.1)
V60135xB						
V60184xB						12.7
V60200xB			495			(28.0)
V60229xB			(19.5)			
V60250xB	216	180		450	245	15.5
V60352xB	(8.5)	(7.1)		(17.7)	(9.6)	(34.2)
V60410xB			523			19.0 (41.9)
V60550xB			(20.6)			51.0 (112.4)
V60835xB						62.0 (136.7)
V61070xB	447	287	618	525	310	63.0 (138.9)
V61230xB	(17.6)	(11.3)	(24.3)	(20.7)	(12.3)	65.0 (143.3)
V61250xB						

EN

## Physical installation

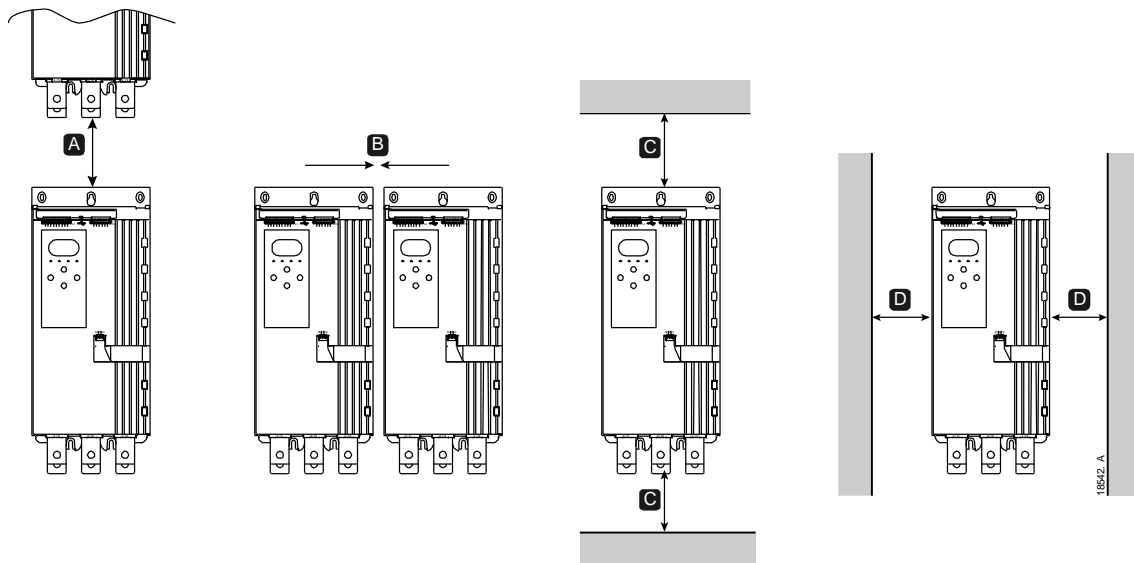

Between starters		Solid surfaces	
A	B	C	D
> 100 mm (3.9 inch)	> 10 mm (0.4 inch)	> 100 mm (3.9 inch)	> 10 mm (0.4 inch)

## Accessories

### Expansion cards

The soft starter offers expansion cards for users requiring additional inputs and outputs or advanced functionality. Each soft starter can support a maximum of one expansion card.

- **Pumping smart card**

The pumping smart card has been designed to support integration with pumping applications and provides the following additional inputs and outputs:

- 3 x digital inputs
- 3 x 4-20 mA transducer inputs
- 1 x RTD input
- 1 x USB-B port
- Remote keypad connector

- **Communications expansion cards**

The soft starter supports network communication via easy-to-install communications expansion cards. Each communications card includes a remote keypad connector port.

Available protocols:

DeviceNet, Ethernet/IP, Modbus RTU, Modbus TCP, Profibus, Profinet.

- **Ground fault protection**

The soft starter can detect ground current and trip before the equipment is damaged.

Ground fault protection requires a 1000:1 or 2000:1 current transformer (not supplied). The CT should be rated for 1 VA or 5 VA. Ground fault protection is available as an option with specific versions of the Modbus RTU, Modbus TCP, Ethernet/IP and Profinet expansion cards.

### **Remote keypad**

The soft starter can be used with a remote keypad, mounted up to 3 metres away from the starter. Each expansion card includes a keypad connection port, or a dedicated keypad connector card is available.

### **Finger guard kit**

Finger guards may be specified for personnel safety. Finger guards fit over the soft starter terminals to prevent accidental contact with live terminals. Finger guards provide IP20 protection when used with cable of diameter 22 mm or greater.

Finger guards are available for models V60200xB~V61250xB.

Finger guards must be fitted to all terminals, even if no cable is connected. Contact your local supplier for assistance selecting the correct finger guard kit.

### **Soft starter management software**

PC software can provide real-time or offline management of soft starters.

- For real-time management in a network of up to 254 starters, the software must connect to the soft starter via a Modbus TCP or Modbus RTU card. The software can monitor, control and program the starter across the network.
- The software can be used to program the starter via the USB port on the pumping smart card.
- For offline management, a configuration file generated in the software can be loaded into the starter via the USB port.

## Main contactor or circuit breaker

A main contactor or circuit breaker should be installed with the soft starter.

- A main contactor is recommended to protect the soft starter from voltage disturbances on the network, while stopped. Select a contactor with an AC3 rating greater than or equal to the full load current rating of the connected motor.
- Use a shunt trip circuit breaker to isolate the motor circuit in the event of a soft starter trip. The shunt trip mechanism must be powered from the supply side of the circuit breaker or from a separate control supply.
- Use the main contactor output (33, 34) to control the main contactor.



### WARNING

When connecting the soft starter in inside delta configuration, always install a main contactor or shunt trip circuit breaker.

## Power factor correction

If power factor correction is used, a dedicated contactor should be used to switch in the capacitors.

To use the soft starter to control power factor correction, connect the PFC contactor to a programmable relay set to Run. When the motor reaches full speed, the relay will close and power factor correction will be switched in. Do not use the soft starter relay output to directly switch in power factor correction.

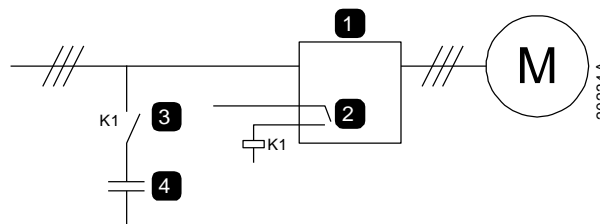

1	Soft starter
2	Programmable output (set = Run)
3	Power factor correction contactor
4	Power factor correction



### CAUTION

Power factor correction capacitors must be connected to the input side of the soft starter. Connecting power factor correction capacitors to the output side will damage the soft starter.

## Short circuit protection devices (SCPD)

Fuses may be installed to protect the soft starter or the installation.

### Type 1 coordination

Type 1 coordination requires that, in the event of a short circuit on the output side of a soft starter, the fault must be cleared without risk of injury to personnel. There is no requirement that the soft starter must remain operational after the fault.

HRC fuses (such as Ferraz/Mersen AJT fuses) can be used for Type 1 coordination according to IEC 60947-4-2 standard.

### Type 2 coordination

Type 2 coordination requires that in the event of a short circuit on the output side of a soft starter, the fault must be cleared without risk of injury to personnel or damage to the soft starter.

Semiconductor fuses for Type 2 circuit protection are additional to HRC fuses or MCCBs that form part of the motor branch circuit protection.



#### CAUTION

DC Brake: A high brake torque setting can result in peak currents up to motor DOL being drawn while the motor is stopping. Ensure protection fuses installed in the motor branch circuit are selected appropriately.



#### CAUTION

Integral solid state short circuit protection does not provide branch circuit protection. Branch circuit protection must be provided in accordance with the National Electrical Code and any additional local codes.

## IEC coordination with short circuit protection devices

HRC fuse codes beginning OFAA are for ABB fuses. All other fuse codes are for Bussmann fuses.

### Models V60024xB~V60550xB

These fuses were selected based on start current of 300% FLC for 10 seconds.

Model	Nominal Rating (A) 300%, 10 s	SCR I <sup>2</sup> t (A <sup>2</sup> s)	Type 1 coordination 480 VAC, 65 kA	Type 2 coordination 690 VAC, 65 kA
V60024xB	24	1150	40NHG000B	170M3010
V60042xB	42	7200	63NHG000B	170M3013
V60052xB	52		80NHG000B	
V60064xB	64	15000	100NHG000B	170M3014
V60105xB	105	80000	160NHG00B	170M3015
V60115xB	115			170M3016
V60135xB	135	125000		170M3016
V60200xB	200	320000	250NHG2B	170M3020
V60229xB	229		315NHG2B	170M3021
V60250xB	250			
V60352xB	352	202000	355NHG2B	170M6009
V60410xB	410	320000	425NHG2B	170M6010
V60550xB	550	781000	630NHG3B	170M6012

### Models V60835xB~V61250xB, bypassed installation

These fuses were selected based on start current of 350% FLC for 30 seconds.

Model	Nominal Rating (A) 350%, 30 s	SCR I <sup>2</sup> t (A <sup>2</sup> s)	Type 1 coordination 500 VAC, 100 kA	Type 2 coordination 690 VAC, 100 kA
V60835xB	565	2530000	1000NHG4G	170M6016
V61070xB	854		1200NHG4G	Not available
V61230xB	1055	3920000	OFAA5GG1250	
V61250xB	1249	7220000		

## Standard fault short circuit

### Models V60024xB~V60550xB

Suitable for use on a circuit capable of delivering up to the stated fault current, 600 VAC maximum, when protected by any UL listed fuses or circuit breakers sized according to the NEC.

Model	Nominal rating (A) 300%, 10 s	3 cycle short cct rating @600 VAC
V60024xB	24	5 kA
V60042xB	42	

Model	Nominal rating (A) 300%, 10 s	3 cycle short cct rating @600 VAC
V60052xB	52	10 kA
V60064xB	64	
V60105xB	105	
V60115xB	120	
V60135xB	135	
V60200xB	225	18 kA
V60229xB	229	
V60250xB	250	
V60352xB	352	
V60410xB	410	30 kA
V60550xB	550	

EN

### Models V60835xB~V61250xB

Suitable for use on a circuit capable of delivering up to the stated fault current, when protected by any circuit breaker or class L fuse sized according to the NEC.

These protection devices were selected based on start current of 350% FLC for 30 seconds.

Model	Nominal Rating (A) 350%, 30 s	@480 VAC or 600 VAC		@480 VAC
		Fault current rating	Fuse rating (A, max) Class L	Circuit breaker rating (A, max)
V60835xB	565	42 kA	1350	1200 A
V61070xB	854			
V61230xB	1055	85 kA	2500	1200 A
V61250xB	1249			1600 A

### High fault short circuit

- Circuit breakers with model codes beginning 3VA/CPD/HMD/HND/HPD are from Siemens.
- Circuit breakers with model codes beginning HFD/HJD/HKD/HLD are from Eaton.
- Circuit breakers with model codes beginning SELA/SFLA/SGLA are from GE.
- Circuit breakers with model codes beginning UTS are from LS Electric or Benschaw.

### Models V60024xB~V60550xB

Suitable for use on a circuit capable of delivering up to the stated fault current, when protected by the specified circuit breaker or by fuses of the stated class and rating.

These protection devices were selected based on start current of 300% FLC for 10 seconds.

Model	Nominal rating (A) 300%, 10 s	@480 VAC		
		Fault current 65 kA		
		Circuit breaker (rating, A)	Fuse rating (A, max)	Fuse class
V60024xB	24	HFD3030 (30 A) SELA36AT0060 (60 A) UTS150H-xxU-040 (40 A) 3VA*140-6****-**** (40A)	30	Any (J, T, K-1, RK1, RK5)
V60042xB	42	HFD3050 (50 A) SELA36AT0060 (60 A) UTS150H-xxU-050 (50 A) 3VA*140-6****-**** (60A)	50	
V60052xB	52	HFD3060 (60 A) SELA36AT0060 (60 A) UTS150H-xxU-060 (60 A) 3VA*140-6****-**** (70A)	60	
V60064xB	64	HFD3100 (100 A) SELA36AT0150 (150 A) UTS150H-xxU-100 (100 A) 3VA*140-6****-**** (100 A)	80	
V60105xB	105	HFD3125 (125 A) SELA36AT0150 (150 A) UTS150H-xxU-125 (125 A) 3VA*225-6****-**** (150 A)	125	J, T, K-1, RK1
V60115xB	115	HFD3125 (125 A) SELA36AT0150 (150 A) UTS150H-xxU-125 (125 A) 3VA*225-6****-**** (150 A)	125	
V60135xB	135	HFD3150 (150 A) SELA36AT0150 (150 A) UTS150H-xxU-150 (150 A) 3VA*225-6****-**** (250 A)	150	



Model	Nominal rating (A) 300%, 10 s	@480 VAC		
		Fault current 65 kA		
		Circuit breaker (rating, A)	Fuse rating (A, max)	Fuse class
V60200xB	200	HJD3250 (250 A) SFLA36AT0250 (250 A) UTS250H-xxU-250 (250 A) 3VA*225-6****-**** (250 A)	225	J, T
V60229xB	229	HJD3250 (250 A) SFLA36AT0250 (250 A) UTS250H-xxU-250 (250 A) 3VA*340-6****-**** (400 A)	250	
V60250xB	250	HKD3300 (300 A) SGLA36AT0400 (400 A) UTS400H-xxU-300 (300 A) 3VA*340-6****-**** (400 A)	300	
V60352xB	352	HLD3400 (400 A) SGLA36AT0600 (600 A) UTS400H-xxU-400 (400 A) HMD63B800 (800 A)	400	Any (J, T, K-1, RK1, RK5)
V60410xB	410	HLD3600 (600 A) SGLA36AT0600 (600 A) UTS600H-xxU-600 (600 A) HND63B100 (1000 A)	450	
V60550xB	550	HLD3600 (600 A) SGLA36AT0600 (600 A) UTS800H-NGx-800 (800 A) HND63B120 (1200 A)	600	

EN

These protection devices were selected based on start current of 350% FLC for 30 seconds.

Model	Nominal rating (A) 350%, 30 s	@600 VAC		
		Fault current 50 kA		Fault current 100 kA
		Circuit breaker (rating, A max)	Fuse rating (A, max)	Fuse class
V60024xB	18	UTS150L-xxU-040 (40 A)	40	Any (J, T, K-1 RK1, RK5)
V60042xB	30	UTS150L-xxU-060 (60 A)	60	
V60052xB	38	UTS150L-xxU-070 (70 A)	70	
V60064xB	52	UTS150L-xxU-100 (100 A)	100	
V60105xB	70	UTS150L-xxU-150 (150 A)	200	
V60115xB	88	UTS150L-xxU-150 (150 A)	250	
V60135xB	105	UTS250L-xxU-250 (250 A)	300	
V60200xB	144	UTS400L-xxU-350 (350 A)	350	Any (J, T, K-1 RK1, RK5)
V60229xB	164	UTS400L-xxU-400 (400 A)	400	
V60250xB	212	UTS800L-NGx-600 (600 A)	500	L
V60352xB	247	UTS800L-NGx-800 (800 A)	700	
V60410xB	404	UTS1200P-NGx-1000 (1000 A)	800	
V60550xB	449	UTS1200P-NGx-1200 (1200 A)	900	

<sup>1</sup> Adjust the continuous current setting of the circuit breaker to match the specified rating.

### Models V60835xB~V61250xB

Suitable for use on a circuit capable of delivering up to the stated fault current, when protected by the specified circuit breaker or by fuses of the stated class and rating.

Fuses: These fuses were selected based on start current of 350% FLC for 30 seconds.

Circuit breakers: Select one of the specified circuit breakers according to the starter's current rating in the application.

Model	Nominal rating (A) 350%, 30 s	@480 VAC		
		Fault current rating	Circuit breaker (rating, A max)	Fuse rating (A, max) Class L
V60835xB	565	65 kA	UTS600H-xxU-600 (600A) UTS800H-NGx-800 (800A) UTS1200H-NGx-1200 (1200A)	1350
		100 kA	UTS600L-xxU-600 (600A) UTS800L-NGx-800 (800A) UTS1200L-NGx-1200 (1200A)	
V61070xB	854	65 kA	UTS600H-xxU-600 (600A) UTS800H-NGx-800 (800A) UTS1200H-NGx-1200 (1200A)	1350
		100 kA	UTS600L-xxU-600 (600A) UTS800L-NGx-800 (800A) UTS1200L-NGx-1200 (1200A)	
V61230xB	1055	65kA	HPD63B160 (1600A)	2500
		100kA	UTS1200L-NGx-1200 (1200A) CPD63B160 (1600A)	
V61250xB	1249	65kA	HPD63B160 (1600A)	
		100kA	UTS1200L-NGx-1200 (1200A) CPD63B160 (1600A)	

Model	Nominal rating (A) 350%, 30 s	@600 VAC		
		Fault current 50 kA	Fault current 65 kA	Fault current 100 kA
		Circuit breaker (rating, A max)	Circuit breaker (rating, A max)	Fuse rating (A, max) Class L
V60835xB	565	HPD63B160 (1600A) UTS1200P-NGx-1200 (1200A)	CPD63B160 (1600A)	1350
V61070xB	854	HPD63B160 (1600A) UTS1200P-NGx-1200 (1200A)	CPD63B160 (1600A)	
V61230xB	1055	HPD63B160 (1600A) UTS1200P-NGx-1200 (1200A)	CPD63B160 (1600A)	2500
V61250xB	1249	HPD63B160 (1600A) UTS1200P-NGx-1200 (1200A)	CPD63B160 (1600A)	

EN

## Specifications

### Supply

Mains voltage (L1, L2, L3)	
V6xxx5B .....	200~525 VAC ( $\pm 10\%$ )
V6xxx6B .....	380~690 VAC ( $\pm 10\%$ )
Control voltage (A1, A2, A3)	
A1, A2 .....	110~120 VAC (+10%/-15%), 600 mA
A2, A3 .....	220~240 VAC (+10%/-15%), 600 mA
Mains frequency .....	50 Hz~60 Hz ( $\pm 5\%$ )
Rated insulation voltage .....	690 VAC
Rated impulse withstand voltage .....	6 kV
Form designation .....	Bypassed or continuous, semiconductor motor starter form 1

### Short circuit capability

Coordination with semiconductor fuses .....	Type 2
Coordination with HRC fuses .....	Type 1

### Electromagnetic capability (compliant with EU Directive 2014/35/EU)

EMC Immunity .....	IEC 60947-4-2
EMC Emissions .....	IEC 60947-4-2 Class B

### Inputs

Input rating .....	Active 24 VDC, 8 mA approx
Motor thermistor (B4, B5) .....	Trip >3.6 k $\Omega$ , reset <1.6 k $\Omega$

### Outputs

Relay outputs .....	10 A @ 250 VAC resistive, 5A @ 250 VAC AC15 pf 0.3
Main contactor (33, 34) .....	Normally open
Bypass contactor (03, 04) .....	Normally open
Relay output A (41, 42, 44) .....	Changeover
Relay output B (53, 54) .....	Normally open
Analog output (21, 22)	
Maximum load .....	600 $\Omega$ (12 VDC @ 20 mA)
Accuracy .....	$\pm 5\%$

### Environmental

Operating temperature .....	-10 °C~60 °C, above 40 °C with derating
Storage temperature .....	-25 °C~+ 60 °C
Operating Altitude .....	0~1000 m, above 1000 m with derating

Humidity .....	5%~95% Relative Humidity
Pollution degree .....	Pollution Degree 3
Vibration .....	IEC 60068-2-6
Protection	
V60024xB~V60135xB .....	IP20
V60200xB~V61250xB .....	IP00

**Heat dissipation**

During start .....	4.5 watts per ampere
During run	
V60024xB~V60052xB .....	≤ 35 watts approx
V60064xB~V60135xB .....	≤ 50 watts approx
V60200xB~V60250xB .....	≤ 120 watts approx
V60352xB~V60550xB .....	≤ 140 watts approx
V60835xB~V61250xB .....	≤ 180 watts approx



**Motor overload protection**

Default: The default settings of parameters 1D, 1E and 1F provide Motor Overload Protection: Class 10, Trip Current 105% of FLA (full load amperage) or equivalent.

**Operational life (internal bypass contacts)**

..... 100 000 operations

**Disposal instructions**

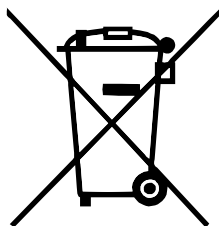

Equipment containing electrical components may not be disposed of together with domestic waste.

It must be collected separately as electrical and electronic waste according to local and currently valid legislation.

## 3 INSTALLATION

# 3



### WARNING

Do not apply mains voltage to the starter until all wiring is complete.



### WARNING

Always apply control voltage before (or with) mains voltage.

### Command source

The soft starter can be started and stopped via the digital inputs, remote keypad, communication network, smart card or scheduled auto-start/stop. The command source can be set via the setup tools, or using parameter 1A *Command Source*.

### Setup procedure overview

1. Mount the soft starter (see *Physical installation* on page 16 for details).
2. Connect control wiring (see *Start/Stop* on page 29 for details).
3. Apply control voltage to the starter.
4. Configure your application:
  1. Press to open the menu.
  2. Press to open the Quick Setup menu.
  3. Scroll through the list to find your application, then press to begin the configuration process (see *Quick setup* on page 38 for details).
5. If your application is not listed in Quick Setup:
  1. Press [**<**] to return to the Menu.
  2. Use [**-**] to scroll to Main Menu and press .
  3. Scroll to Motor Details and press , then press [**-**] then to edit parameter 1B *Motor Full Load Current*.
  4. Set parameter 1B to match the motor's full load current (FLC).
  5. Press to save the setting.
6. Close the Menu by pressing [**<**] repeatedly.

7. (Optional) Use the built-in simulation tools to check that the control wiring is connected correctly (see *Run simulation* on page 40).
8. Power off the soft starter.
9. Connect the motor cables to starter output terminals 2/T1, 4/T2, 6/T3.
10. Connect mains supply cables to starter input terminals 1/L1, 3/L2, 5/L3 (see *Power terminations* on page 33).

The soft starter is now ready to control the motor.

## Inputs



### CAUTION

The control inputs are powered by the soft starter. Do not apply external voltage to the control input terminals.





### NOTICE

Cables to the control inputs must be segregated from mains voltage and motor cabling.

EN

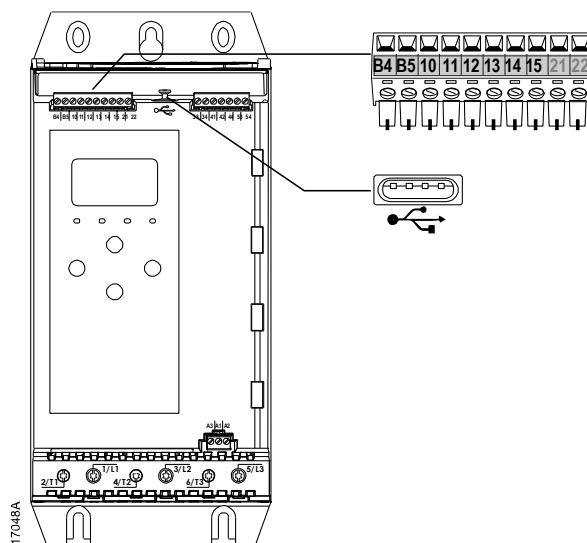
## Input terminals



B4, B5	Motor thermistor input
10, 11	Reset input
11, 12	Start/stop input
13, 14	Programmable input A (default = Input Trip (N/O))
13, 15	Programmable input B (default = Input Trip (N/O))
	USB port

### Motor thermistor

Motor thermistors can be connected directly to the soft starter. The soft starter will trip when the resistance of the thermistor circuit exceeds approximately 3.6 k $\Omega$  or falls below 20  $\Omega$ .

The thermistors must be wired in series. The thermistor circuit should be run in screened cable and must be electrically isolated from earth and all other power and control circuits.



#### NOTICE

The thermistor input is disabled by default, but activates automatically when a thermistor is detected. If thermistors have previously been connected to the soft starter but are no longer required, use the Thermistor Reset function to disable the thermistor. Thermistor Reset is accessed via the Setup Tools.

### Reset/starter disable

The reset input (10, 11) is normally closed by default. The soft starter will not perform a start if the reset input is open. The display will show "Not Ready".

If the reset input opens while the soft starter is running, the starter will remove power and allow the motor to coast to stop.



#### NOTICE

The reset input can be configured for normally open or normally closed operation. Use parameter 71 *Reset/Enable Logic*.

### Start/stop

The soft starter requires two-wire control.

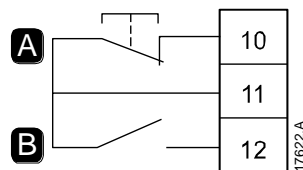

A	Reset
B	Start/Stop



#### WARNING

If the start input is closed when control voltage is applied, the starter will attempt to start.

Check that the start/stop input is open before applying control voltage.



#### NOTICE

The soft starter will only accept commands from the control inputs if parameter 1A *Command Source* is set to Digital Input.



## Programmable inputs

The programmable inputs (13, 14 and 13, 15) allow external equipment to control the starter.

The operation of the programmable inputs is controlled by parameters 7A~7H.

## USB port

The USB port can be used to upload a configuration file, or download parameter settings and event log information from the starter. See *USB save & load* on page 41 for details.

## Outputs

### Output terminals

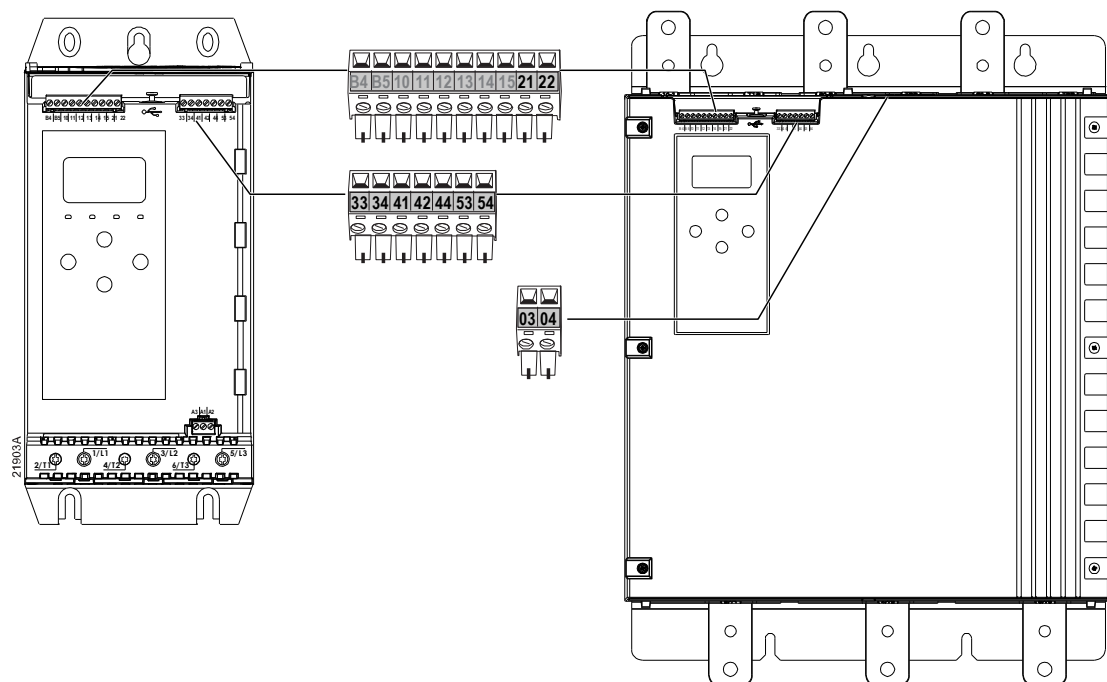

21, 22	Analog output
33, 34	Main contactor output
41, 42, 44	Relay output A (default = Run)
53, 54	Relay output B (default = Run)
03, 04	Bypass contactor output

### Analog output

The soft starter has an analog output, which can be connected to associated equipment to monitor motor performance.

The operation of the analog output is controlled by parameters 9A~9D.

## Main contactor output

The main contactor output (33, 34) closes as soon as the soft starter receives a start command and remains closed while the soft starter is controlling the motor (until the motor starts a coast to stop, or until the end of a soft stop). The main contactor output will also open if the soft starter trips.

The main contactor output can also be used to control a shunt trip circuit breaker.



### NOTICE

Use parameter 20H *Shunt Trip Mode* to configure the soft starter for use with a main contactor or circuit breaker.

- For use with a main contactor, use the default setting of "Disable"
- For use with a circuit breaker, set 20H to "Enable"

*Soft starter installed with main contactor*

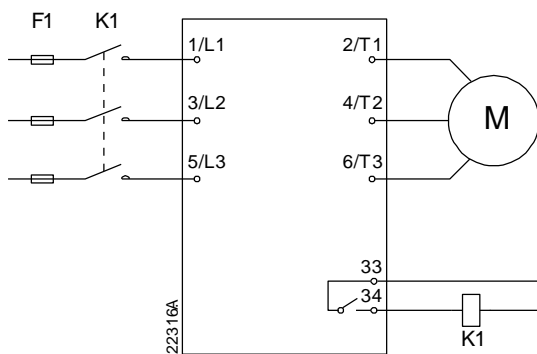

*Soft starter installed with a shunt relay and circuit breaker*

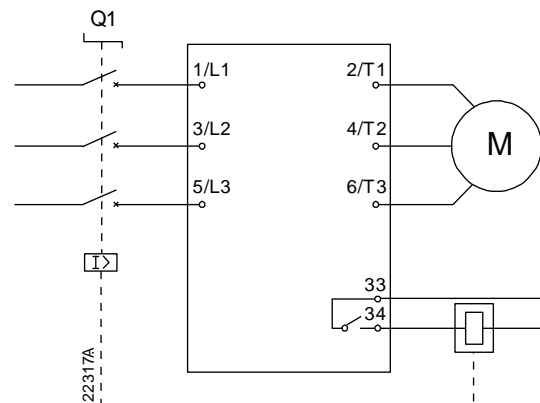

<b>F1</b>	Fuses
<b>K1</b>	Main contactor

<b>Q1</b>	Circuit breaker
-----------	-----------------



### CAUTION

Some electronic contactor coils are not suitable for direct switching with PCB mount relays. Consult the contactor manufacturer/supplier to confirm suitability.

## Programmable outputs

The programmable outputs (41, 42, 44 and 53, 54) can report the status of the starter, or can be used to control associated equipment.

The operation of the programmable outputs is controlled by parameters 8A~8F.

### Control voltage

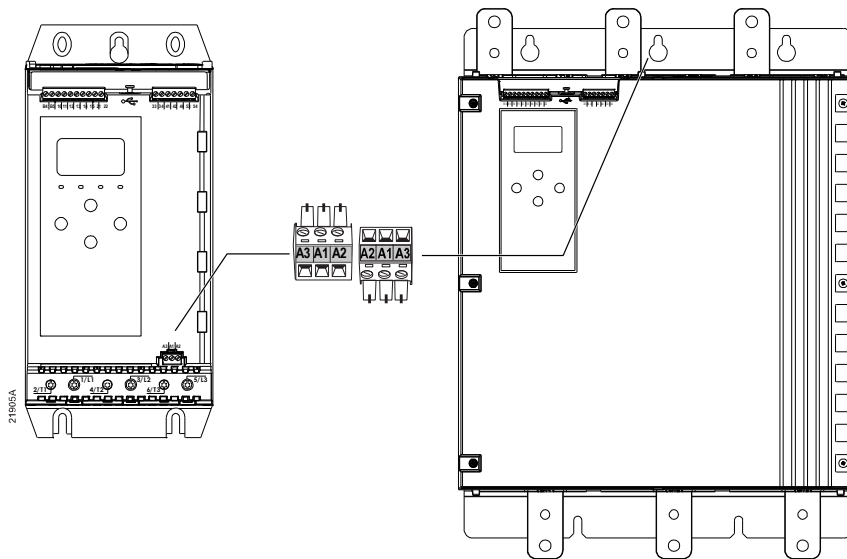

- 110~120 VAC: A1, A2
- 220~240 VAC: A2, A3

Install supplementary or branch overcurrent protection on the control circuit supply (A1, A2, A3), in accordance with the electrical code applicable at the installation location.

### Power terminations

For models V60024xB~V60550xB, the power input and output terminals are at the bottom of the unit. For models V60835xB~V61250xB, the power input is at the top and the output is at the bottom.

V60024xB~ V60135xB

V60200xB~ V60550xB

V60835xB~ V61250xB

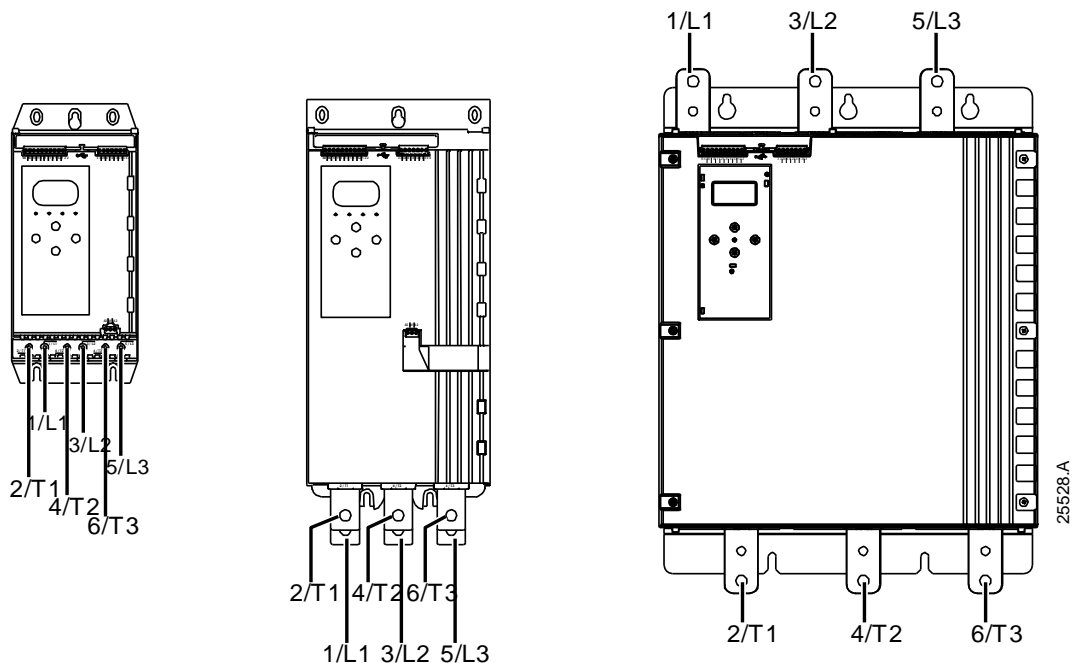

- Models V60024xB~V60135xB use cage clamps. Use only copper stranded or solid conductors, rated for 75 °C or higher.
- Models V60200xB~V60550xB use busbars at the bottom of the unit. Use copper or aluminium conductors, stranded or solid, rated for 60 °C/75 °C.
- Models V60835xB~V61250xB use busbars. Input terminals are at the top of the unit and output terminals are at the bottom.

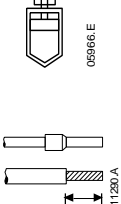
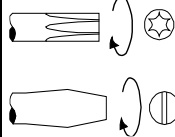
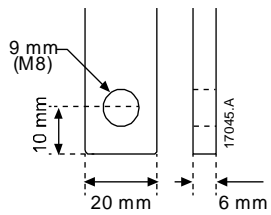
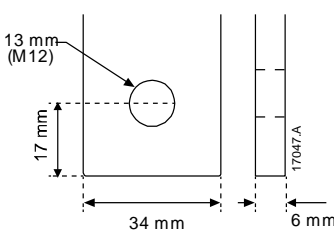
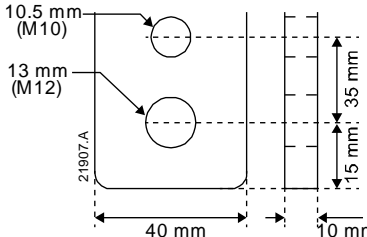
V60024xB~V60135xB		
 <p>Cable size: 6-70 mm<sup>2</sup> (AWG 10-2/0) Torque: 4 Nm (2.9 ft-lb) 14 mm (0.55 inch)</p>	 <p>Torx T20 x 150 Flat 7 mm x 150</p>	
V60200xB~0250B	V60352xB~V60550xB	V60835xB~V61250xB
<p>19 Nm (14.0 ft-lb)</p> 	<p>66 Nm (49.0 ft-lb)</p> 	<p>66 Nm (49.0 ft-lb)</p> 



**NOTICE**

If the installation requires large diameter cables, it is possible to complete each termination with two smaller cables, one on each side of the busbar.



**NOTICE**

When connecting power terminations, we recommend cleaning the surface contact area thoroughly (using an emery or stainless steel brush) and using an appropriate jointing compound to prevent corrosion.

**Wiring connectors**

Select a connector according to the wire size, material and your application requirements.

• **Models V60024xB~V60550xB**

A compression connector is recommended for models V60200B to 0550B. The recommended crimping tool is TBM8-750.

Model	Example connector – aluminium cable	Example connector – copper cable
V60200xB	61165	60156
V60229xB	61171	60165
V60250xB		
V60352xB	61162	60150
V60410xB	61165	60162
V60550xB	61178	60171

• **Models V60835xB~V61250xB**

A terminal lug is recommended for models V60835xB~V61250xB. The recommended lug is TCAL125.

To use a lug, models V60835xB~V61250xB require busbar link 995-22395-00.



**Motor connection**

The soft starter can be connected to the motor in-line or inside delta (also called three-wire and six-wire connection). When connecting in inside delta, enter the motor full load current (FLC) for parameter 1B. The soft starter will automatically detect whether the motor is connected in-line or inside delta and will calculate the correct inside delta current level.



**NOTICE**

If the starter is not correctly detecting the motor connection, use parameter 20F *Motor Connection*.

**In-line installation, internally bypassed**

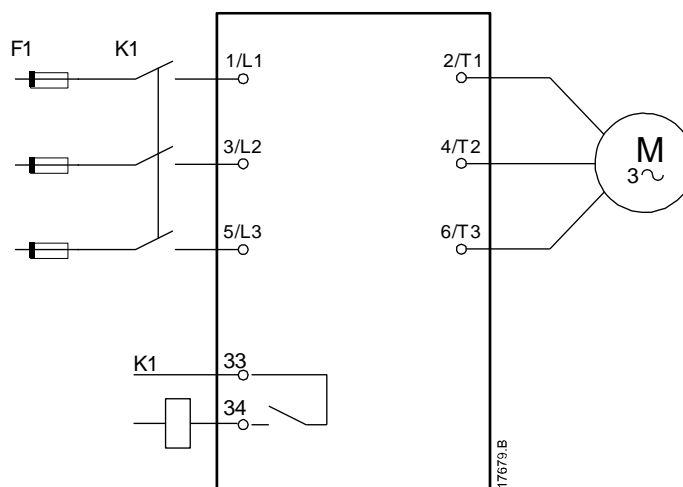

K1	Main contactor (strongly recommended)
F1	Fuses or circuit breaker

33, 34	Main contactor output
--------	-----------------------

### Inside delta installation, internally bypassed

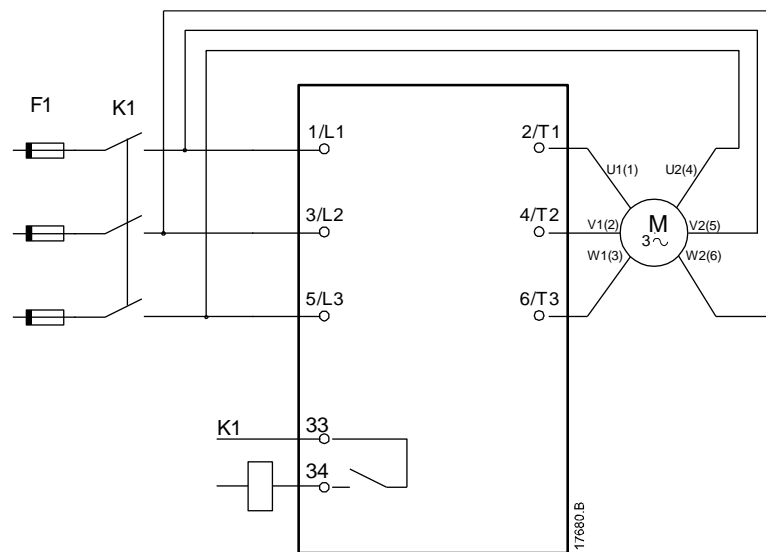

K1	Main contactor
F1	Fuses or circuit breaker
33, 34	Main contactor output



#### WARNING

When connecting the soft starter in inside delta configuration, always install a main contactor or shunt trip circuit breaker.



#### NOTICE

When connecting in inside delta, enter the motor full load current (FLC) for parameter 1B. The soft starter will automatically detect whether the motor is connected in-line or inside delta and will calculate the correct inside delta current level.

## Earth terminations

Models V60835xB~V61250xB have earth terminals on each side of the starter, near the top back corner. Either earth point may be used.

Models V60024xB~V60550xB do not require a protective earth connection. All internal conductive parts are fully enclosed by a non-conductive outer case.

## Typical installation

### Internally bypassed installation

The soft starter is installed with a main contactor (AC3 rated). Control voltage must be supplied from the input side of the contactor.

The main contactor is controlled by the main contactor output (33, 34).

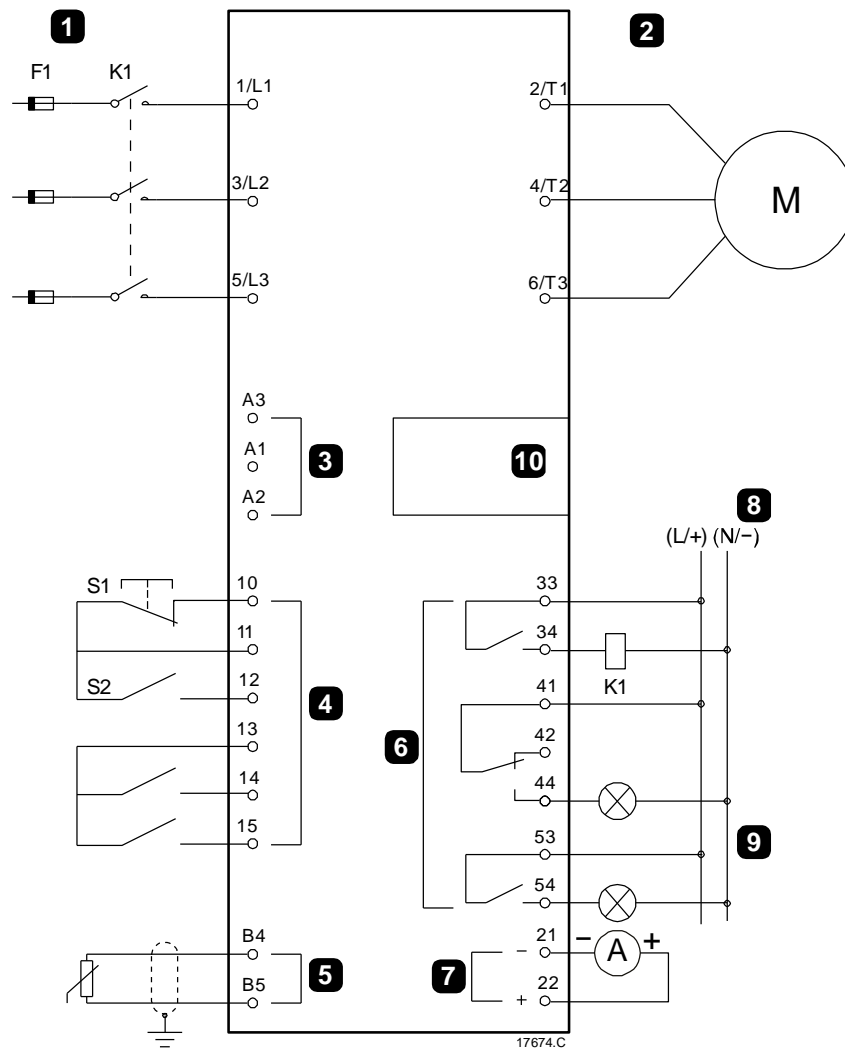

EN

1	Three-phase supply
2	Motor
3	Control voltage (soft starter)
4	Digital inputs
5	Motor thermistor input
6	Relay outputs
7	Analog output
8	Control voltage (external equipment)
9	Pilot lamps
10	Communications / Smart card expansion port

K1	Main contactor
F1	Fuses or circuit breaker
10, 11 (S1)	Reset
11, 12 (S2)	Start/Stop
13, 14	Programmable input A (default = Input Trip (N/O))
13, 15	Programmable input B (default = Input Trip (N/O))
B4, B5	Motor thermistor input
33, 34	Main contactor output
41, 42, 44	Relay output A (default = Run)
53, 54	Relay output B (default = Run)
21, 22	Analog output

## Quick setup

The Quick Setup Menu makes it easy to configure the soft starter for common applications. The starter guides you through the most common installation parameters, and suggests a typical setting for the application. You can adjust each parameter to suit your exact requirements.

All other parameters remain at default values. To change other parameter values or review the default settings, use the menu (see *Parameter list* for details).

Always set parameter 1B *Motor Full Load Current* to match the motor's nameplate full load current.

Application	Start Mode	Start Ramp Time (seconds)	Initial Current (%)	Current Limit (%)	Adaptive Start Profile	Stop Mode	Stop Time (seconds)	Adaptive Stop Profile
Pump Centrifugal	Adaptive Control	10	200	500	Early accel.	Adaptive Control	15	Late decel.
Pump bore	Adaptive Control	3	200	500	Early accel.	Adaptive Control	3	Late decel.
Pump Hydraulic	Constant Current	2	200	350	n/a	Coast Stop To	n/a	n/a
Fan Damped	Constant Current	2	200	350	n/a	Coast Stop To	n/a	n/a
Fan Undamped	Constant Current	2	200	450	n/a	Coast Stop To	n/a	n/a
Compressor Screw	Constant Current	2	200	400	n/a	Coast Stop To	n/a	n/a
Compressor Recip	Constant Current	2	200	450	n/a	Coast Stop To	n/a	n/a
Conveyor	Constant Current	5	200	450	n/a	Coast Stop To	n/a	n/a
Bow thruster	Constant Current	5	100	400	n/a	Coast Stop To	n/a	n/a
Bandsaw	Constant Current	2	200	450	n/a	Coast Stop To	n/a	n/a



### NOTICE

The Adaptive Start and Stop Profile settings only apply when using Adaptive Control. The settings are ignored for all other start and stop modes.



## 4 SETUP TOOLS

# 4

Setup Tools includes options to load or save parameters to a backup file, set the starter's network address, check the status of the inputs and outputs, reset the thermal models or test operation using the run simulation.

To access the Setup Tools, press  $\equiv$  to open the menu then select Setup Tools.

### Set date and time

To set the date and time:

1. Press  $\equiv$  to open the menu then select Setup Tools.
11. Scroll to Set Date & Time.
12. Press the  $\equiv$  button to enter edit mode.
13. Press the  $\equiv$  and [ $\leftarrow$ ] buttons to select which part of the date or time to edit.
14. Use the [ $+$ ] and [ $-$ ] buttons to change the value.
15. Press  $\equiv$  after the last digit to save the setting. When the action has been completed, the screen will briefly display a confirmation message, then return to the previous menu level.

### Command source

The soft starter can be started and stopped via the digital inputs, remote keypad, communication network, smart card or scheduled auto-start/stop. The command source can be set via the setup tools, or using parameter 1A *Command Source*.

If the remote keypad is installed, the **LOCAL/REMOTE** button provides shortcut access to the Command Source function in Setup Tools.

### Commissioning

Commissioning lets the starter be started and stopped via the local keypad. Use the [ $+$ ] and [ $-$ ] buttons to select a function, then press  $\equiv$  to send the selected command to the starter. The available functions are:

- Quick stop (coast to stop)/Reset
- Start
- Stop

## Run simulation

The run simulation simulates a motor starting, running and stopping to confirm that the soft starter and associated equipment have been installed correctly.



### NOTICE

The soft starter must be disconnected from mains voltage.

The simulation is only available when the soft starter is in Ready state.

To use the run simulation:

1. Press to open the menu then select Setup Tools.
2. Scroll to Run Simulation and press .
3. Apply a start command from the selected command source. The soft starter simulates its pre-start checks and closes the main contactor relay. The Run LED flashes.
4. Press . The soft starter simulates starting.
5. Press . The soft starter simulates running.
6. Apply a stop command from the selected command source. The soft starter simulates stopping. The Run LED flashes.
7. Press . The Ready LED flashes and the main contactor relay opens.
8. Press . The soft starter activates then deactivates each programmable output.
9. Press to return to the setup tools.

```
Run Simulation
Ready
Apply Start Signal
```

```
Run Simulation
Pre-Start Checks
MENU to Continue
```

```
Run Simulation
ATTENTION!
Remove Mains Volts
MENU to Continue
```

```
Run Simulation
Starting X:XXs
MENU to Continue
```

```
Run Simulation
Running
Apply Stop Signal
```

```
Run Simulation
Stopping X:XXs
MENU to Continue
```

```
Run Simulation
Stopped
MENU to Continue
```

```
Run Simulation
Prog Relay A
On
MENU to Continue
```



## Load/save settings

Load/save settings allows users to:

- Reset parameters to default values
- Load parameter settings from an internal file
- Save the current parameter settings to an internal file

The internal file contains default values until a user file is saved.

To load or save parameter settings:

1. Press  to open the menu then select Setup Tools.
2. Scroll to Load/Save Settings and press the  button.
3. Scroll to the required function and press the  button.

Load/Save
Settings
Load Defaults
Load User Set
Save User Set

4. At the confirmation prompt, select YES to confirm or NO to cancel, then press  to proceed.

Load Defaults
No
Yes

When the action has been completed, the screen will briefly display a confirmation message, then return to the previous menu level.

## USB save and load

The USB save and load menu lets you:

- Save parameter settings and all event log entries to an external file (CSV format)
- Save parameter settings to an external file (proprietary format)
- Load parameter settings from a previously saved external file
- Load custom messages to display on the keypad when a programmable input is active



### NOTICE

The soft starter supports FAT32 file systems. The soft starter's USB functions are not compatible with NTFS file systems.

### Save and load procedure

1. Connect the external drive to the USB port.

2. Press **≡** to open the menu then select Setup Tools.
3. Scroll to USB Save & Load and press **≡**.
4. Scroll to the required function and press the **≡** button.

```

USB Save & Load
Save Params and
Logs
Save Master Params
Load Master Params
    
```

5. At the confirmation prompt, select YES to confirm or NO to cancel, then press **≡** to proceed.

```

Save Params and
Logs
No
Yes
    
```

When the action has been completed, the screen will briefly display a confirmation message, then return to the previous menu level.

### File locations and formats

Function	File location
Save Parameters and Logs	The starter will create a directory at the top level of the USB drive, named with the soft starter's serial number. The event log and parameter settings are saved as individual CSV files, and the soft starter's software and system information are saved to a text file.
Save Master Parameters	The starter will create a file called Master_Parameters.par, in the top level of the USB drive.
Load Master Parameters	The starter will load the file Master_Parameters.par from the top level of the USB drive. This file can be created or edited using the soft starter management software.
Load Custom Message	The starter will load the files Custom_Message_A.txt and Custom_Message_B.txt from the top level of the USB drive.

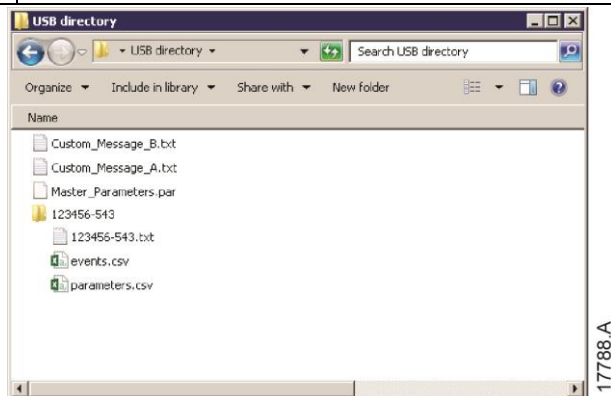

### Auto-start/stop

The starter can be configured to automatically start and/or stop the motor at a particular time, or run it in cycles of a specified duration.

The Auto-Start/Stop option in Setup Tools gives quick access to the auto-start/stop parameters.

1. Press **≡** to open the menu then select Setup Tools.
2. Scroll to Auto-Start/Stop and press the **≡** button.
3. Scroll to the required function and press the **≡** button.

```
Auto-Start/Stop
Start/Stop Mode
Start/Stop Sunday
Start/Stop Monday
```

4. Adjust the settings as required:  
Press the **≡** and **[<]** buttons to select which information to edit.  
Use the **[+]** and **[-]** buttons to change the value.

```
Start/Stop Sunday
Start/Stop Disable
Start Time:          00:00
Stop Time:           00:00
```

5. To save changes, press the **≡** button. The soft starter will confirm the changes. To cancel changes, press the **[<]** button.

EN

## Network address

To use the soft starter on an Ethernet network, separate addresses must be configured for:

- IP Address
- Gateway Address
- Subnet Mask

To set the network addresses:

1. Press **≡** to open the menu then select Setup Tools.
2. Scroll to Network Address and press the **≡** button.
3. Scroll to the required function and press the **≡** button.
4. The first digit of the address will be highlighted.
5. Use **[<]** and **≡** to select which digit to alter. Use the **[+]** and **[-]** buttons to change the value.
6. Press **≡** after the last digit to save the setting.

```
Set IP Address
192.168.000.002
```

When the action has been completed, the screen will briefly display a confirmation message, then return to the previous menu level.



### NOTICE

The network address can also be set using parameters 12H~12S.



**NOTICE**

To configure the soft starter for use with other communication protocols, use parameters 12A~12G.

**Digital I/O state**

The top line of the screen shows the start/stop, reset and programmable inputs.

The bottom line of the screen shows the fixed main contactor output, then programmable outputs A and B.

```

Digital I/O State
Inputs:  00000000
Outputs: 00000000
    
```

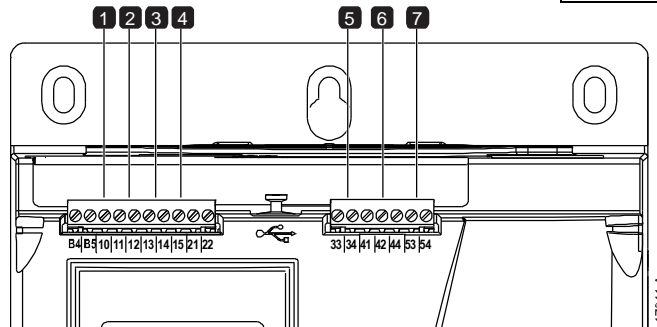

1	10, 11: Reset input
2	11, 12: Start/stop input
3	13, 14: Programmable input A
4	13, 15: Programmable input B

5	33, 34: Main contactor output
6	41, 42, 44: Relay output A
7	53, 54: Relay output B

**Analog I/O state**

The top line of the screen shows the state of the motor thermistor input.

The bottom line of the screen shows the value of the analog output.

```

Analog I/O State
Thermistor:      0
4-20mA Output:  04.0 mA
    
```

Thermistor input:

- S = Short
- H = Hot
- C = Cold
- O = Open

**Serial number and rating**

The top line of the screen shows the product name.

The middle line shows the unit's serial number.

The bottom line of the screen shows the model number.

```

Serial Number & Rating
V6
123456-123
0410-V5-S1-C1
    
```

## Software versions

The software versions screen reports the version of each software component in the starter:

- user interface
- motor control
- remote keypad (if connected)
- parameter list
- bootloader
- expansion card (if fitted)



### NOTICE

Updated software, including alternative languages, can be loaded into the starter via the USB port if required. Contact your local supplier for further information.

EN

## Thermistor reset

The thermistor input is disabled by default, but activates automatically when a thermistor is detected. If thermistors have previously been connected to the soft starter but are no longer required, use the Thermistor Reset function to disable the thermistor.

## Reset thermal model

The soft starter's thermal modelling software constantly monitors the motor's performance. This allows the starter to calculate the motor's temperature and ability to start successfully at any time.

The thermal model can be reset if required.



### CAUTION

Resetting the motor thermal model will compromise thermal model protection and may compromise motor life. Only reset the thermal model in an emergency.

## 5 LOGS

# 5

The Logs Menu provides information on events, trips and starter performance.

To access the Logs Menu on the local keypad, press  to open the menu then select Logs. On the remote keypad, press **LOGS**.

### Event log

The event log stores details of the starter's most recent trips, warnings, and operations (including starts, stops and configuration changes).

Event 1 is the most recent and event 384 is the oldest stored event.



#### NOTICE



The event log can be exported to an external file for analysis away from the starter. See *USB save and load* on page 41 for details.



### Counters

The counters store statistics on the starter's operation:

- Hours run (lifetime and since counter last reset)
- Number of starts (lifetime and since counter last reset)
- Number of times the thermal model has been reset

To view the counters:

1. Open the Logs.
2. Scroll to counters and press .
3. Use the **[+]** and **[-]** buttons to scroll through the counters. Press  to view details.

To reset a counter, press  then use the **[+]** and **[-]** buttons to select Reset/Do Not Reset. Press  to confirm the action.

To close the counter and return to the Logs, press .

### QR code

The soft starter can generate a QR code which allows a smartphone to display key information about the starter, including serial number, firmware



versions and installed options, plus details of the starter's three most recent trips. This information can be useful when requesting assistance from your local supplier.

**NOTICE**

You must install the soft starter support app in order to read the QR code. Contact your local supplier for further information.

# 6 KEYPAD AND FEEDBACK



## The keypad

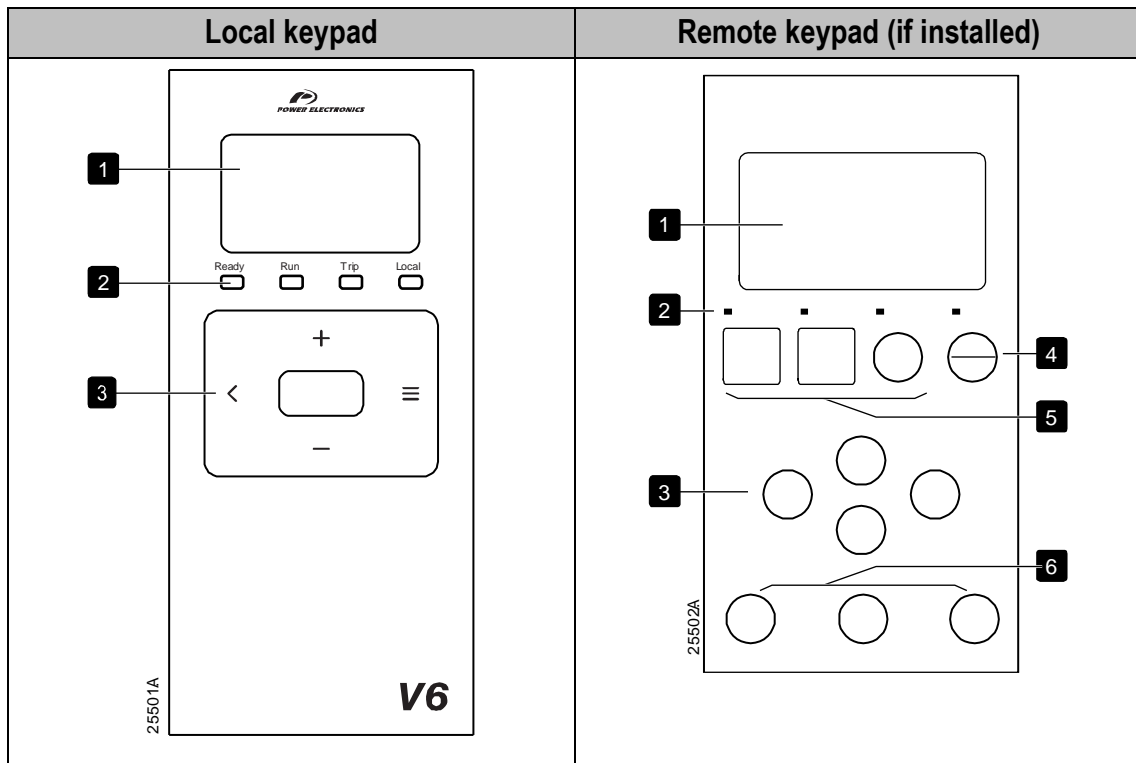

<b>1</b>	Four-line display for status and programming details.
<b>2</b>	Status LEDs
<b>3</b>	Menu navigation buttons: [<]: Exit the menu or parameter, or cancel a parameter change. On the local keypad, this button also resets a trip. ≡: Enter a menu or parameter, or save a parameter change. [+ [-]: Scroll to the next or previous menu or parameter, change the setting of the current parameter or scroll through the status screens.
<b>4</b>	Shortcut to the command source menu in Setup Tools.
<b>5</b>	Soft starter local control buttons
<b>6</b>	Shortcut buttons for quick access to common tasks. <b>LOGS:</b> Open the Logs Menu. <b>GRAPH:</b> Select which graph to view, or pause/restart the graph (hold longer than 0.5 seconds) <b>TOOLS:</b> Open the Setup Tools.

## Remote keypad

The remote keypad can be used to control the soft starter if parameter 1A *Command Source* is set to 'Remote Keypad'.

- If the remote keypad is not selected as the command source, the **START**, **STOP** and **RESET** buttons will have no effect.
- The menu navigation buttons and display on the remote keypad are always active.
- If a button is pressed on the starter's local keypad, the display on the remote keypad will update to match.



### NOTICE

The remote keypad can be safely connected or removed while the starter is running. It is not necessary to remove mains or control voltage.



### NOTICE

If parameter 1A *Command Source* is set to Remote Keypad, removing the remote keypad will cause a trip.

## Lighten/darken the display

The backlight on the display can be adjusted:

- to lighten the display, hold down the [**<**] button and press the [**+**] key
- to darken the display, hold down the [**<**] button and press the [**-**] key



### NOTICE

The local and remote keypads can be adjusted independently.

## Starter status LEDs

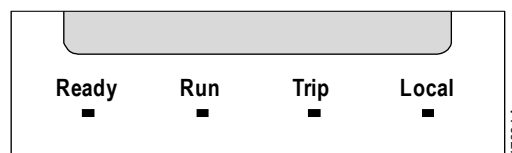



Phase Currents		
000.0A	000.0A	000.0A

### Last start information

The last start information screen shows details of the most recent successful start:

- start duration (seconds)
- maximum start current drawn (as a percentage of motor full load current)
- calculated rise in motor temperature

Last start	010 s
350 % FLC	Δ Temp 5%

### User configurable screen

The programmable screen can be configured to show the most important information for the particular application. Use parameters 10J ~ 10M to select which information to display.

Mains Frequency	59.7 Hz
Motor pf	0.95
Motor Power	37.0 kW
Motor Temperature	85%

### Date and time

The date/time screen shows the current system date and time (24 hour format). For details on setting the date and time, see *Set date and time* on page 39.

### Performance graph

The performance graph provides a real-time display of operating performance. Use parameters 10B~10E to format the graph.

The display on the main keypad shows information for motor current.

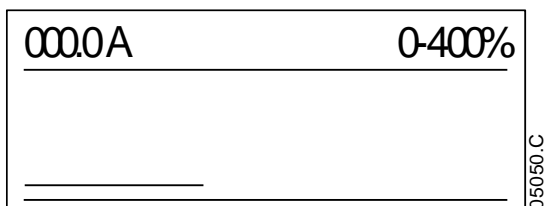

If a remote keypad is connected, press **GRAPHS** to change the graph data. The graph can show:

- motor current

- motor temperature
- motor pf
- analog input data from the smart card (if installed)

# 7 OPERATION

## 7

EN

### Start, stop and reset commands

The soft starter can be started and stopped via the digital inputs, remote keypad, communication network, smart card or scheduled auto-start/stop. The command source can be set via the setup tools, or using parameter 1A *Command Source*.

- The soft starter will only accept Start and Reset commands from the designated command source.
- The soft starter will accept Stop commands from the designated command source, but can be forced to stop by opening the reset input, or by opening the start/stop input during an auto-start/stop cycle.
- The programmable input can be used to override the selected command source (see parameter 7A *Input A Function*).

### Command override

The programmable input (13, 14) can be used to override the command source, for situations where the normal control mechanism has been lost. Set parameter 7A *Input A Function* to the alternative command source (eg 'Command Override: Keypad').

While the input is active, the starter will only accept commands from the selected override source. To restore control to the command source selected in parameter 1A *Command Source*, reopen the input.

### Auto-start/stop

The starter can be configured to automatically start and/or stop the motor at a particular time, or run it in cycles of a specified duration.



#### NOTICE

Start delay, restart delay and auto-reset delay all apply to auto-start operation.

### Clock mode

The starter can start and/or stop the motor once per day.

For clock mode to operate:

- parameter 4A *Auto-Start/Stop Mode* must be set to 'Enable'
- parameter 1A *Command Source* must be set to 'Clock'
- the reset input must be closed
- the start input (11, 12) must be active. This allows the soft starter to be stopped via the digital inputs in an emergency.

Clock mode operation is controlled by parameters 4D ~ 4X.

### Timer mode

The starter can automatically stop the motor after a specified run time, then restart it after a specified off (stopped) time. The starter will repeat the cycle while the start signal remains active.

For timer mode to operate:

- parameter 4A *Auto-Start/Stop Mode* must be set to 'Enable'
- parameter 1A *Command Source* must be set to 'Timer'
- the reset input must be closed
- the first start must be commanded by a start signal

Timer mode operation is controlled by parameters 4B ~ 4C.

## PowerThrough

PowerThrough allows the soft starter to control the motor even if the soft starter is damaged on one phase. The soft starter will use two-phase control techniques to soft start and soft stop the motor.

PowerThrough does not support adaptive control soft starting or soft stopping. In PowerThrough, the soft starter will use constant current soft starting and timed voltage ramp soft stopping. If PowerThrough is enabled, parameters 2C and 2D must be set appropriately.



### NOTICE

The starter will trip on Lx-Tx Shorted on the first start attempt after control power is applied. PowerThrough will not operate if control power is cycled between starts.

- PowerThrough is only available with in-line installations. If the starter is installed inside delta, PowerThrough will not operate.
- PowerThrough remains active until '3-Phase Control Only' is reselected. While operating in PowerThrough, the trip LED will flash and the display will indicate '2 Phase - Damaged SCR'.



**CAUTION**

PowerThrough uses a two-phase soft start technology and additional care is required when sizing circuit breakers and protection. Contact your local supplier for assistance.

**Emergency mode**

Emergency mode allows the soft starter to run the motor and ignore trip conditions.

Emergency mode is controlled via a programmable input (input A 13, 14 or input B 13, 15) and parameter *7A Input A Function*/*7E Input B Function* must be set to 'Emergency Mode'. A closed circuit across 13, 14 activates emergency mode. When the soft starter receives a start command, it will continue to run until a stop command is received, ignoring all trips and warnings.

Emergency mode can be used in conjunction with any command source.

**NOTICE**

Although emergency mode operation satisfies the functionality requirements of Fire Mode, we do not recommend its use in situations that require testing and/or compliance with specific standards as it is not certified.

**CAUTION**

Continued use of emergency mode is not recommended. Emergency mode may compromise the starter and/or motor life as all protections and trips are disabled.

**Using the starter in emergency mode will void the product warranty.**

**Auxiliary trip**

An external trip circuit (such as a low pressure alarm switch for a pumping system) can be used to trip the soft starter and stop the motor. The external circuit is connected to a programmable input (input A 13, 14 or input B 13, 15). To control the behaviour of the trip, set the following parameters:

- Parameter *7A Input A Function*: select 'Input Trip (N/O)'.  
• Parameter *7B Input A Trip*: set as required. For example, 'Run Only' limits the input trip to when the soft starter is running only.

- Parameter *7C Input A Trip Delay*: sets a delay between the input activating and the soft starter tripping.
- Parameter *7D Input A Initial Delay*: sets a delay before the soft starter monitors the state of the input, after the start signal. For example, a delay may be required to allow time for pipeline pressure to build up.
- Parameter *7J Input A Name*: select a name, eg 'Input A Trip' (optional).

## Typical control methods

The requirements of an application differ between each installation, but the methods listed below are often a good starting point for common applications.

Application	Start Mode	Start Ramp Time (seconds)	Initial Current (%FLC)	Current Limit (%FLC)	Stop Mode	Stop Time (seconds)
Bow thruster	Constant Current	5	100	400	Coast To Stop	n/a
Centrifuge (Separator)	Constant Current	1	200	450	Coast To Stop	n/a
Chipper	Constant Current	1	200	450	Coast To Stop	n/a
Compressor - reciprocating - loaded	Constant Current	1	200	450	Coast To Stop	n/a
Compressor - reciprocating - unloaded	Constant Current	1	200	400	Coast To Stop	n/a
Compressor - screw - loaded	Constant Current	1	200	400	Coast To Stop	n/a
Compressor - screw - unloaded	Constant Current	1	200	350	Coast To Stop	n/a
Conveyor - horizontal	Constant Current	5	200	400	TVR Soft Stop	10
Conveyor - inclined	Constant Current	2	200	450	Coast To Stop	n/a
Conveyor - vertical (bucket)	Constant Current	2	200	450	Coast To Stop	n/a
Crusher - cone	Constant Current	1	200	350	Coast To Stop	n/a
Crusher - jaw	Constant Current	1	200	450	Coast To Stop	n/a
Crusher - rotary	Constant Current	1	200	400	Coast To Stop	n/a
Debarker	Constant Current	1	200	350	Coast To Stop	n/a
Fan - axial (damped)	Constant Current	1	200	350	Coast To Stop	n/a
Fan - axial (undamped)	Constant Current	1	200	450	Coast To Stop	n/a
Fan - centrifugal (damped)	Constant Current	1	200	350	Coast To Stop	n/a

Application	Start Mode	Start Ramp Time (seconds)	Initial Current (%FLC)	Current Limit (%FLC)	Stop Mode	Stop Time (seconds)
Fan - centrifugal (undamped)	Constant Current	1	200	450	Coast To Stop	n/a
Fan - high pressure	Constant Current	1	200	450	Coast To Stop	n/a
Mill - ball	Constant Current	1	200	450	Coast To Stop	n/a
Mill - hammer	Constant Current	1	200	450	Coast To Stop	n/a
Pump - bore	Adaptive Control (Early accel.)	3	n/a	500	Adaptive Control (Late decel.)	3
Pump - centrifugal	Adaptive Control (Early accel.)	10	n/a	500	Adaptive Control (Late decel.)	15
Pump - Hydraulic	Constant Current	2	200	350	Coast To Stop	n/a
Pump - positive displacement	Adaptive Control (Const. accel.)	10	n/a	400	Adaptive Control (Const. decel.)	10
Pump - submersible	Adaptive Control (Early accel.)	5	n/a	500	Adaptive Control (Late decel.)	5
Saw - bandsaw	Constant Current	1	200	450	Coast To Stop	n/a
Saw - circular	Constant Current	1	200	350	Coast To Stop	n/a
Shredder	Constant Current	1	200	450	Coast To Stop	n/a

## Soft start methods

### Constant current

Constant current is the traditional form of soft starting, which raises the current from zero to a specified level and keeps the current stable at that level until the motor has accelerated.

Constant current starting is ideal for applications where the start current must be kept below a particular level.

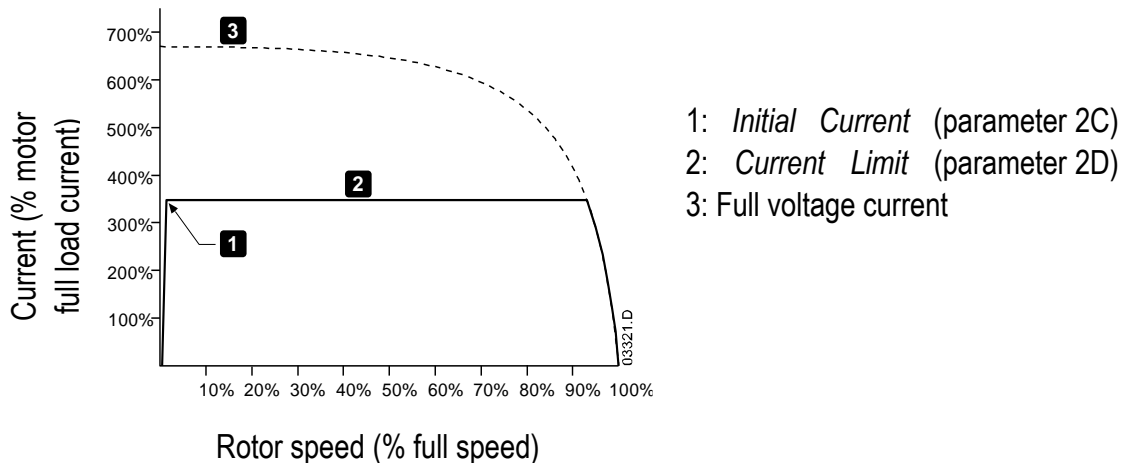

### Constant current with current ramp

Current ramp soft starting raises the current from a specified starting level (1) to a maximum limit (3), over an extended period of time (2).

Current ramp starting can be useful for applications where:

- the load can vary between starts (for example a conveyor which may start loaded or unloaded). Set the initial current (parameter 2C) to a level that will start the motor with a light load, and the current limit (parameter 2D) to a level that will start the motor with a heavy load.
- the load breaks away easily, but starting time needs to be extended (for example a centrifugal pump where pipeline pressure needs to build up slowly).
- the electricity supply is limited (for example a generator set), and a slower application of load will allow greater time for the supply to respond.

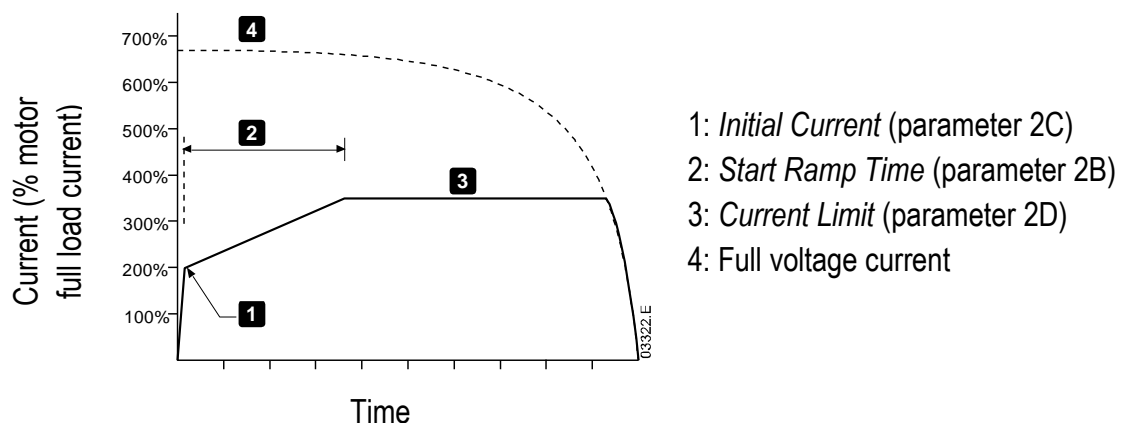

### Constant current with kickstart

Kickstart provides a short boost of extra torque at the beginning of a start, and can be used in conjunction with current ramp or constant current starting.

Kickstart can be useful to help start loads that require high breakaway torque but then accelerate easily (for example helical rotor pumps).

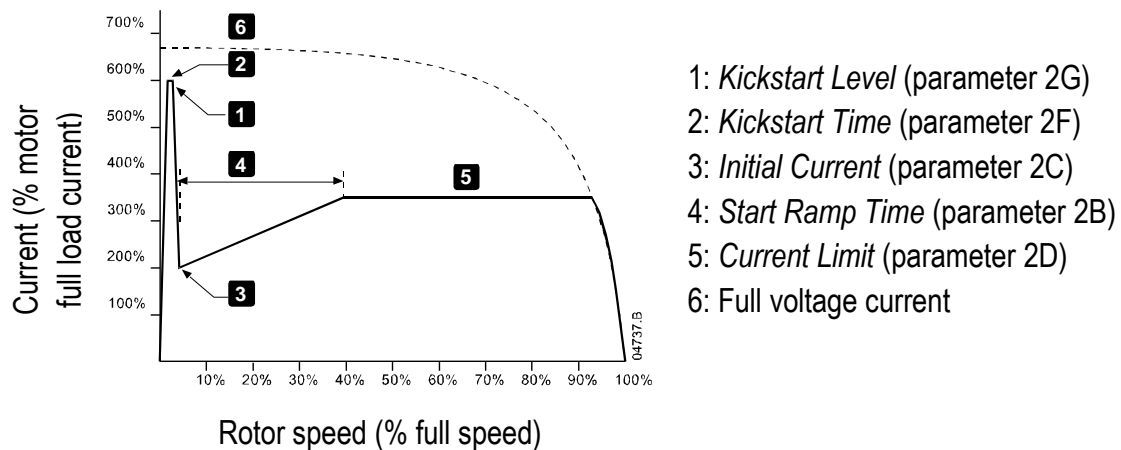

### Timed voltage ramp

Timed voltage ramp (TVR) soft starting ramps the application of voltage to the motor over a defined time period. The voltage ramp reduces the initial starting torque and slows the motor's rate of acceleration.

TVR starting can be useful for applications where multiple motors of different sizes are connected in parallel, and/or the loads are not mechanically linked.



#### NOTICE

TVR soft starting is not suitable for high inertia loads (such as fans), which require a high level of voltage to accelerate the load.



#### NOTICE

For multiple motors of the same sizes, and/or mechanically coupled loads, use constant current starting.

For a timed voltage ramp start, the following are typical values and can be adjusted to suit your specific application:

- Add the FLC value of all the connected motors. Use this combined value to set parameter 1B *Motor Full Load Current*. (Note that the combined value must not exceed the starter rating.)
- Set parameter 2C *Initial Current* to 100%, parameter 2D *Current Limit* to 500%, and set the ramp time as required (parameter 2B *Start Ramp Time*).

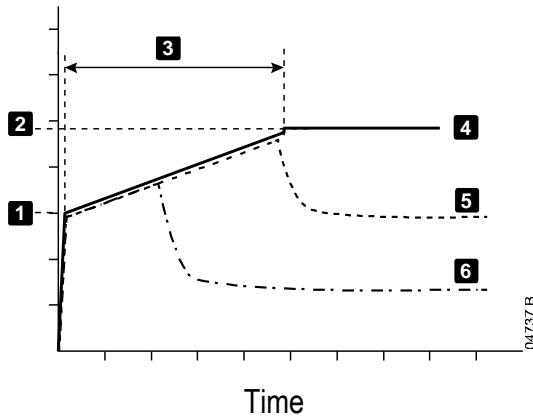

### Adaptive control for starting

In an adaptive control soft start, the soft starter adjusts the current in order to start the motor within a specified time and using a selected acceleration profile.



#### NOTICE

The soft starter will apply the current limit on all soft starts, including adaptive control. If the current limit is too low or the start ramp time (parameter 2B) is too short, the motor may not start successfully.

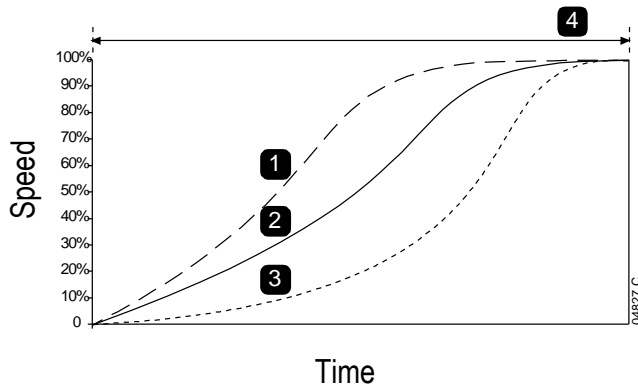

#### • Fine-tuning Adaptive Control

If the motor does not start or stop smoothly, adjust the adaptive control gain (parameter 2L). The gain setting determines how much the soft starter will adjust future adaptive control starts and stops, based on information from the previous start. The gain setting affects both starting and stopping performance.

- If the motor accelerates or decelerates too quickly at the end of a start or stop, increase the gain setting by 5%~10%.
- If the motor speed fluctuates during starting or stopping, decrease the gain setting slightly.

**NOTICE**

The soft starter tunes Adaptive Control to match the motor. Changing the following parameters will reset Adaptive Control and the first start/stop cycle will use constant current start/timed voltage ramp stop: 1B *Motor Full Load Current*, 2D *Current Limit*, 2L *Adaptive Control Gain*.

## Stop methods

### Coast to stop

Coast to stop lets the motor slow at its natural rate, with no control from the soft starter. The time required to stop will depend on the type of load.

### Timed voltage ramp soft stop

Timed voltage ramp stopping reduces the voltage to the motor gradually over a defined time. This can extend the stopping time of the motor and may avoid transients on generator set supplies.

**NOTICE**

The load may continue to run after the stop ramp is complete.

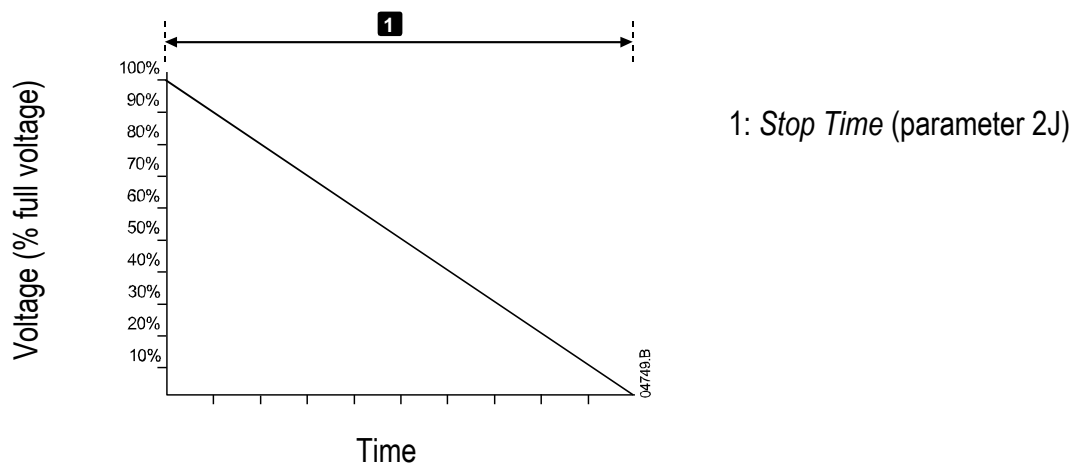

### Adaptive control for stopping

In an adaptive control soft stop, the soft starter controls the current in order to stop the motor within a specified time and using a selected deceleration profile. Adaptive Control can be useful in extending the stopping time of low inertia loads.

If adaptive control is selected, the first soft stop will use timed voltage ramp. This allows the soft starter to learn the characteristics of the connected motor. This motor data is used by the soft starter during subsequent adaptive control stops.



**NOTICE**

Adaptive control does not actively slow the motor down and will not stop the motor faster than a coast to stop. To shorten the stopping time of high inertia loads, use brake.



**CAUTION**

Adaptive Control controls the motor's speed profile, within the programmed time limit. This may result in a higher level of current than traditional control methods.

If replacing a motor connected to a soft starter programmed for Adaptive Control starting or stopping, the starter will need to learn the characteristics of the new motor. Change the value of parameter 1B *Motor Full Load Current* or parameter 2L *Adaptive Control Gain* to initiate the re-learning process. The next start will use constant current and the next stop will use timed voltage ramp.

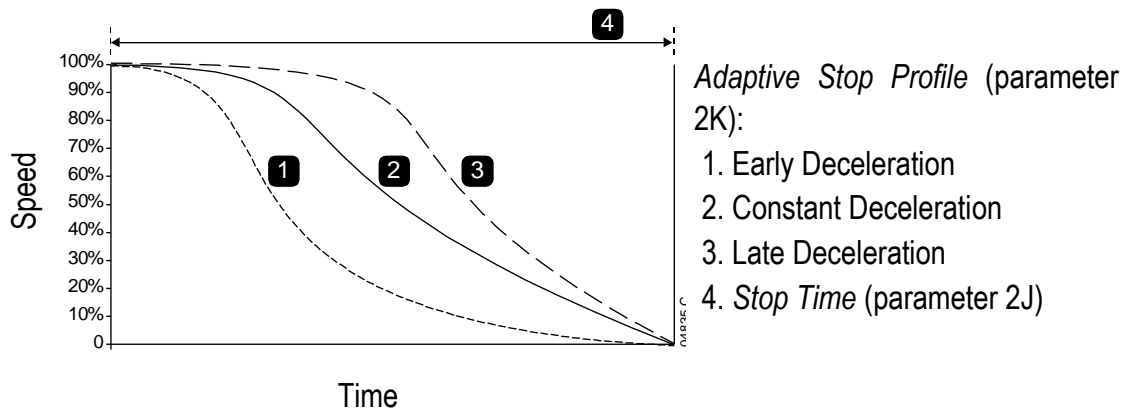

Adaptive Control is ideal for pumping applications, where it can minimise the damaging effects of fluid hammer. We recommend testing the three profiles to identify the best profile for the application.

Adaptive Stop Profile	Application
Late Deceleration	High head systems where even a small decrease in motor/pump speed results in a rapid transition between forward flow and reverse flow.
Constant Deceleration	Low to medium head, high flow applications where the fluid has high momentum.
Early Deceleration	Open pump systems where fluid must drain back through the pump without driving the pump in reverse.

**DC brake**

Brake reduces the time required to stop the motor.

During braking an increased noise level from the motor may be audible. This is a normal part of motor braking.



**CAUTION**

When using DC brake, the mains supply must be connected to the soft starter (input terminals L1, L2, L3) in positive phase sequence.

**CAUTION**

If the brake torque is set too high, the motor will stop before the end of the brake time and the motor will suffer unnecessary heating which could result in damage. Careful configuration is required to ensure safe operation of the starter and motor.

A high brake torque setting can result in peak currents up to motor DOL being drawn while the motor is stopping. Ensure protection fuses installed in the motor branch circuit are selected appropriately.

**CAUTION**

Brake operation causes the motor to heat faster than the rate calculated by the motor thermal model. If you are using brake, install a motor thermistor or allow sufficient restart delay (parameter 5P).

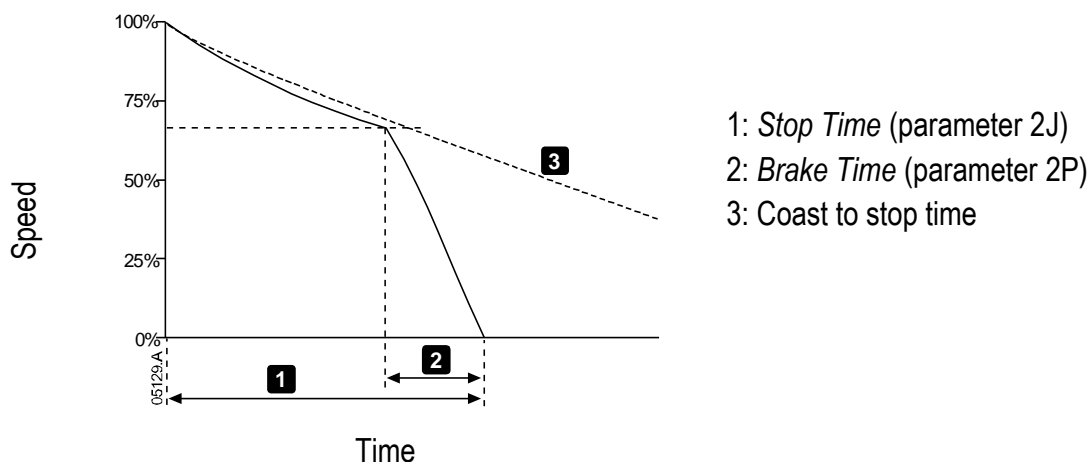

Parameter settings:

- Parameter 2I *Stop Mode*: set to 'DC Brake'.
- Parameter 2J *Stop Time*: This is the total braking time (1) and must be set sufficiently longer than the brake time (parameter 2P) to allow the pre-braking stage to reduce motor speed to approximately 70%. If the stop time is too short, braking will not be successful and the motor will coast to stop.
- Parameter 2O *DC Brake Torque*: set as required to slow the load. If set too low, the motor will not stop completely and will coast to stop after the end of the braking period.
- Parameter 2P *DC Brake Time*: Set Brake Time (parameter 2P) to approximately one quarter of the programmed Stop Time. This sets the time for the Full Brake stage (2).

## Soft brake

For applications with high inertia and/or a variable load requiring the maximum possible braking torque, the soft starter can be configured for soft braking.

The soft starter uses a changeover relay to control forward run and braking contactors. While braking, the soft starter reverses the phase sequence to the motor and supplies reduced current, gently slowing the load.

When motor speed approaches zero, the zero speed sensor (A2) stops the soft starter and opens the braking contactor (K2).

Soft braking can be used with both the primary and secondary motor sets, and must be configured separately for each.

Parameter settings:

- Parameter 2I *Stop Mode*: set to 'Soft Brake'
- Parameter 2Q *Brake Current Limit*: set as required to slow the load
- Parameter 2R *Soft Brake Delay*: controls the time the soft starter will wait after a stop signal is received, before it begins to supply braking current to the motor. Set to allow time for K1 and K2 to switch.
- Parameter 7A *Input A Function*: set to 'Zero Speed Sensor'
- Parameter 8A *Relay A Function*: set to 'Soft Brake Relay'

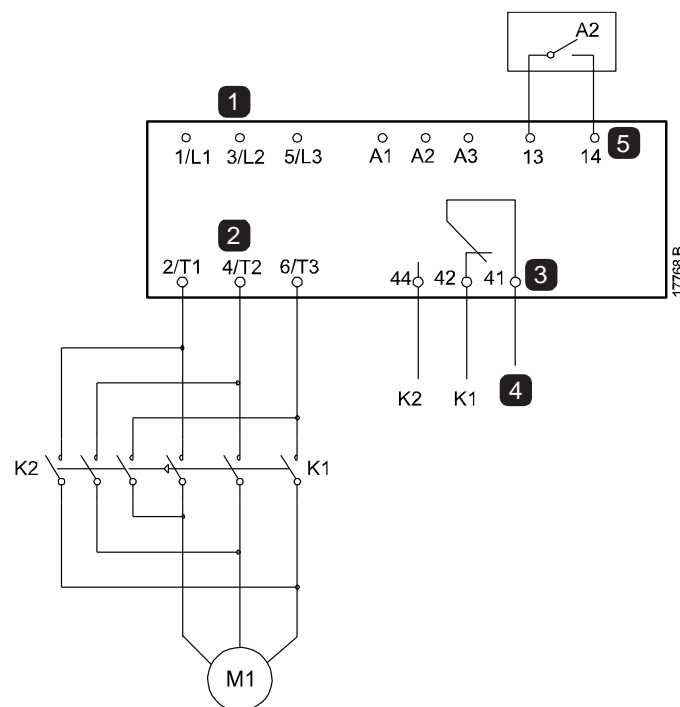

1	Three-phase supply
2	Motor terminals
3	Relay output A
4	K1/K2 coil supply
5	Programmable input A

K1	Line contactor (Run)
K2	Line contactor (Brake)
A2	Zero speed sensor

## Pump clean

The starter can perform a pump clean function before soft starting the motor. This can help dislodge debris from the impeller.

Pump clean starts the motor in reverse then forward direction, then stops the motor. Pump clean can be configured to repeat the process up to 5 times. After the specified number of cleaning cycles, the starter performs the programmed soft start.

Pump clean operation is controlled by the start/stop input (11, 12). A programmable input must be set to pump clean (see parameter 7A *Input A Function* for details) and the input must be closed when the start signal is applied.

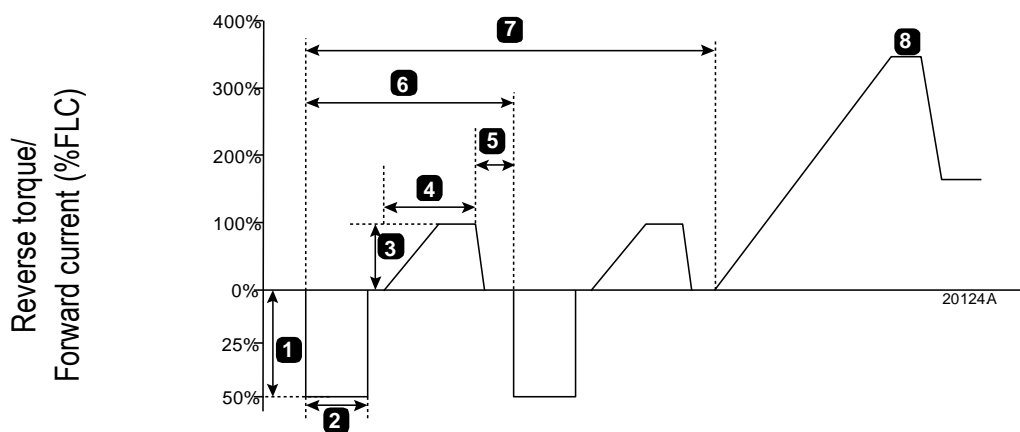

1	Reverse Torque (parameter 11A)
2	Reverse Time (parameter 11B)
3	Forward Current Limit (parameter 11C)
4	Forward Time (parameter 11D)

5	Pump Stop Time (parameter 11F)
6	Cleaning cycle
7	Pump Clean Cycles (parameter 11G)
8	Programmed soft start

## Reverse direction operation

The starter can control a reversing contactor, to operate the motor in reverse direction. When reverse operation is selected, the starter will perform a soft start using the opposite phase sequence from normal operation.

EN

Reverse operation is controlled by the start/stop input (11, 12). A programmable input must be set to reverse direction (parameter 7A *Input A Function*) and an output must be set to reversing contactor (parameter 8A *Relay A Function*).

The input must be closed when the start signal is applied. The starter will keep the reverse relay in the same state until the end of the starting/stopping cycle.

This example shows a simple installation, but many different configurations are possible depending on your application requirements. Contact your local supplier for an application note showing more installation options.



**NOTICE**

The first start after the direction is changed will be constant current.



**NOTICE**

If phase sequence protection is required, install the reversing contactor on the output (motor) side of the soft starter.

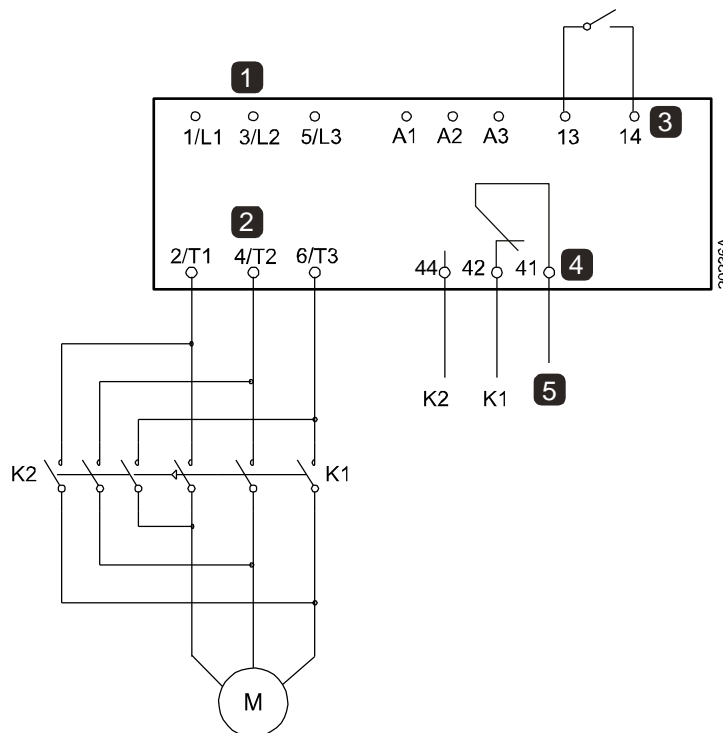

1	Three-phase supply
2	Motor terminals
3	Programmable input A (set = Reverse Direction)
4	Relay output A (set = Reversing Contactor)
5	K1/K2 coil supply

K1	Forward run contactor
K2	Reversing contactor

## Jog operation

Jog runs the motor at reduced speed, to allow alignment of the load or to assist servicing. The motor can be jogged in either forward or reverse direction.

Jog is only available when the starter is controlled via the digital inputs (parameter 1A *Command Source* = 'Digital Input'). To operate in jog, a programmable input must be set to jog (see parameter 7A for details) and the input must be closed when the start signal is applied.



### CAUTION

Slow speed running is not intended for continuous operation due to reduced motor cooling.

Jog operation causes the motor to heat faster than the rate calculated by the motor thermal model. If you are using jog, install a motor thermistor or allow sufficient restart delay (parameter 5P).

The maximum available torque for jog forward is approximately 50%~75% of motor full load torque (FLT) depending on the motor. The torque when the motor is jogged in reverse is approximately 25% to 50% of FLT.

Parameters 2H and 3J *Jog Torque* control how much of the maximum available jog torque the soft starter will apply to the motor.



### NOTICE

Torque settings above 50% may cause increased shaft vibration.

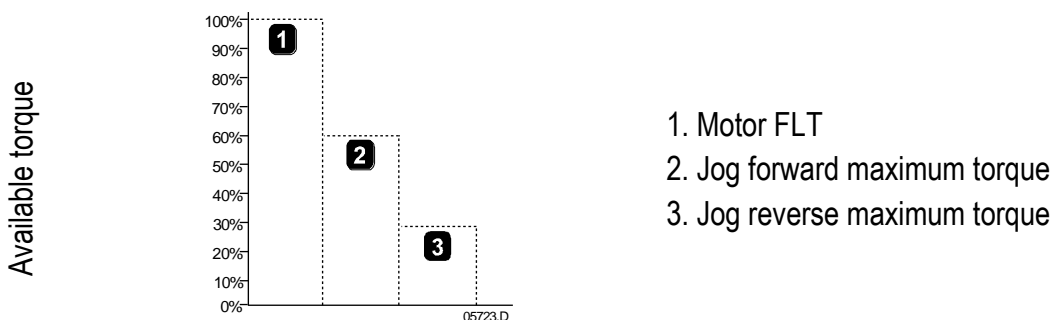

## Inside delta operation

When connecting in inside delta, enter the motor full load current (FLC) for parameter 1B. The soft starter will automatically detect whether the motor is connected in-line or inside delta and will calculate the correct inside delta current level.

Adaptive Control, Jog, Brake and PowerThrough functions are not supported with inside delta (six-wire) operation. If these functions are programmed when the starter is connected inside delta the behaviour is as given below:

Unsupported option	Replacement behaviour
Adaptive control start	The starter performs a constant current start.
Adaptive control stop	If parameter 2J <i>Stop Time</i> is set >0 seconds, the starter performs a TVR soft stop. If parameter 2J is set to 0 seconds the starter performs a coast to stop.
Jog	The starter issues a warning with the error message <i>Unsupported option</i> .
DC brake	The starter performs a coast to stop.
Soft brake	The starter performs a coast to stop.
PowerThrough	The starter trips with the error message <i>Lx-Tx Shorted</i> .

**NOTICE**

When connected in inside delta, the soft starter will not detect phase loss on T2 during run.

**NOTICE**

If the starter is not correctly detecting the motor connection, use parameter 20F *Motor Connection*.

## Secondary motor set

The soft starter can be programmed with two separate starting and stopping profiles. This allows the soft starter to control the motor in two different starting and stopping configurations.

The secondary motor set is ideal for dual winding (Dahlander) motors, multi-motor applications, or situations where the motor may start in two different conditions (such as loaded and unloaded conveyors).

The secondary motor set can also be used for duty/standby applications.

**NOTICE**

For duty/standby applications, set parameter 6Q *Motor Overtemperature* to Log Only and install temperature protection for each motor.

To use the secondary motor set, a programmable input must be set to 'Motor Set Select' and the input must be closed before a start command is given (see 7A *Input A Function* and 7E *Input B Function*). The soft starter checks which motor set to use at a start, and will use that motor set for the entire start/stop cycle.



# 8 PROGRAMMABLE PARAMETERS

## 8

EN

### Main menu

The main menu lets you view and change programmable parameters that control how the soft starter operates.

To open the main menu, press the  button then scroll to Main Menu and press  again.





#### NOTICE

Parameters for smart card functions are only visible in the parameter list if the smart card is installed.

### Altering parameter values

To change a parameter value:

- scroll to the appropriate parameter in the main menu and press  to enter edit mode.
- to alter the parameter setting, use the **[+]** and **[-]** buttons. Pressing **[+]** or **[-]** once will increase or decrease the value by one unit. If the button is held for longer than five seconds, the value will increase or decrease at a faster rate.
- to save changes, press . The setting shown on the display will be saved and the keypad will return to the parameter list.
- to cancel changes, press **[<]**. The keypad will ask for confirmation, then return to the parameter list without saving changes.

### Adjustment lock

You can prevent users from altering parameter settings by turning on the adjustment lock (parameter 10G *Adjustment Lock*).

If a user attempts to change a parameter value when the adjustment lock is active, an error message is displayed:

```
Access Denied
Adj Lock is On
```

## Parameter list

	Parameter Group	Default Setting
<b>1</b>	<b>Motor Details</b>	
1A	<i>Command Source</i>	Digital Input
1B	<i>Motor Full Load Current</i>	Model dependent
1C	<i>Motor kW</i>	0 kW
1D	<i>Locked Rotor Time</i>	00:10 (mm:ss)
1E	<i>Locked Rotor Current</i>	600%
1F	<i>Motor Service Factor</i>	105%
1G	<i>Reserved</i>	
<b>2</b>	<b>Motor Start/Stop</b>	
2A	<i>Start Mode</i>	Constant Current
2B	<i>Start Ramp Time</i>	00:10 (mm:ss)
2C	<i>Initial Current</i>	200%
2D	<i>Current Limit</i>	350%
2E	<i>Adaptive Start Profile</i>	Constant Acceleration
2F	<i>Kickstart Time</i>	000 ms
2G	<i>Kickstart Level</i>	500%
2H	<i>Jog Torque</i>	50%
2I	<i>Stop Mode</i>	TVR Soft Stop
2J	<i>Stop Time</i>	00:00 (mm:ss)
2K	<i>Adaptive Stop Profile</i>	Constant Deceleration
2L	<i>Adaptive Control Gain</i>	75%
2M	<i>Multi Pump</i>	Single Pump
2N	<i>Start Delay</i>	00:00 (mm:ss)
2O	<i>DC Brake Torque</i>	20%
2P	<i>DC Brake Time</i>	00:01 (mm:ss)
2Q	<i>Brake Current Limit</i>	250%
2R	<i>Soft Brake Delay</i>	400 ms
<b>3</b>	<b>Motor Start/Stop 2</b>	
3A	<i>Motor Full Load Current-2</i>	Model dependent
3B	<i>Motor kW-2</i>	0 kW
3C	<i>Start Mode-2</i>	Constant Current
3D	<i>Start Ramp Time-2</i>	00:10 (mm:ss)
3E	<i>Initial Current-2</i>	200%
3F	<i>Current Limit-2</i>	350%
3G	<i>Adaptive Start Profile-2</i>	Constant Acceleration
3H	<i>Kickstart Time-2</i>	000 ms



	<b>Parameter Group</b>	<b>Default Setting</b>
3I	<i>Kickstart Level-2</i>	500%
3J	<i>Jog Torque-2</i>	50%
3K	<i>Stop Mode-2</i>	TVR Soft Stop
3L	<i>Stop Time-2</i>	00:00 (mm:ss)
3M	<i>Adaptive Stop Profile-2</i>	Constant Deceleration
3N	<i>Adaptive Control Gain-2</i>	75%
3O	<i>Multi Pump-2</i>	Single Pump
3P	<i>Start Delay-2</i>	00:00 (mm:ss)
3Q	<i>DC Brake Torque-2</i>	20%
3R	<i>DC Brake Time-2</i>	00:01 (mm:ss)
3S	<i>Brake Current Limit-2</i>	250%
3T	<i>Soft Brake Delay-2</i>	400 ms
<b>4</b>	<b>Auto-Start/Stop</b>	
4A	<i>Auto-Start/Stop Mode</i>	Disable
4B	<i>Run Time</i>	00:00 (hh:mm)
4C	<i>Stopped Time</i>	00:00 (hh:mm)
4D	<i>Sunday Mode</i>	Start/Stop Disable
4E	<i>Sunday Start Time</i>	00:00 (hh:mm)
4F	<i>Sunday Stop Time</i>	00:00 (hh:mm)
4G	<i>Monday Mode</i>	Start/Stop Disable
4H	<i>Monday Start Time</i>	00:00 (hh:mm)
4I	<i>Monday Stop Time</i>	00:00 (hh:mm)
4J	<i>Tuesday Mode</i>	Start/Stop Disable
4K	<i>Tuesday Start Time</i>	00:00 (hh:mm)
4L	<i>Tuesday Stop Time</i>	00:00 (hh:mm)
4M	<i>Wednesday Mode</i>	Start/Stop Disable
4N	<i>Wednesday Start Time</i>	00:00 (hh:mm)
4O	<i>Wednesday Stop Time</i>	00:00 (hh:mm)
4P	<i>Thursday Mode</i>	Start/Stop Disable
4Q	<i>Thursday Start Time</i>	00:00 (hh:mm)
4R	<i>Thursday Stop Time</i>	00:00 (hh:mm)
4S	<i>Friday Mode</i>	Start/Stop Disable
4T	<i>Friday Start Time</i>	00:00 (hh:mm)
4U	<i>Friday Stop Time</i>	00:00 (hh:mm)
4V	<i>Saturday Mode</i>	Start/Stop Disable
4W	<i>Saturday Start Time</i>	00:00 (hh:mm)
4X	<i>Saturday Stop Time</i>	00:00 (hh:mm)

	<b>Parameter Group</b>	<b>Default Setting</b>
<b>5</b>	<b>Protection Levels</b>	
5A	<i>Current Imbalance</i>	30%
5B	<i>Current Imbalance Delay</i>	00:03 (mm:ss)
5C	<i>Undercurrent</i>	20%
5D	<i>Undercurrent Delay</i>	00:05 (mm:ss)
5E	<i>Overcurrent</i>	400%
5F	<i>Overcurrent Delay</i>	00:00 (mm:ss)
5G	<i>Undervoltage</i>	350 V
5H	<i>Undervoltage Delay</i>	00:01 (mm:ss)
5I	<i>Overvoltage</i>	500 V
5J	<i>Overvoltage Delay</i>	00:01 (mm:ss)
5K	<i>Underpower</i>	10%
5L	<i>Underpower Delay</i>	00:05 (mm:ss)
5M	<i>Overpower</i>	150%
5N	<i>Overpower Delay</i>	00:05 (mm:ss)
5O	<i>Excess Start Time</i>	00:20 (mm:ss)
5P	<i>Restart Delay</i>	00:10 (mm:ss)
5Q	<i>Starts per Hour</i>	0
5R	<i>Phase Sequence</i>	Any Sequence
<b>6</b>	<b>Protection Actions</b>	
6A	<i>Auto-Reset Count</i>	0
6B	<i>Auto-Reset Delay</i>	00:05 (mm:ss)
6C	<i>Current Imbalance</i>	Soft Trip and Log
6D	<i>Undercurrent</i>	Soft Trip and Log
6E	<i>Overcurrent</i>	Soft Trip and Log
6F	<i>Undervoltage</i>	Soft Trip and Log
6G	<i>Overvoltage</i>	Soft Trip and Log
6H	<i>Underpower</i>	Log Only
6I	<i>Overpower</i>	Log Only
6J	<i>Excess Start Time</i>	Soft Trip and Log
6K	<i>Input A Trip</i>	Soft Trip and Log
6L	<i>Input B Trip</i>	Soft Trip and Log
6M	<i>Network Communications</i>	Soft Trip and Log
6N	<i>Remote Keypad Fault</i>	Soft Trip and Log
6O	<i>Frequency</i>	Soft Trip and Log
6P	<i>Phase Sequence</i>	Soft Trip and Log
6Q	<i>Motor Overtemperature</i>	Soft Trip and Log
6R	<i>Motor Thermistor Circuit</i>	Soft Trip and Log

	<b>Parameter Group</b>	<b>Default Setting</b>
6S	<i>Shorted SCR Action</i>	3-Phase Control Only
6T	<i>Battery/Clock</i>	Soft Trip and Log
<b>7</b>	<b>Inputs</b>	
7A	<i>Input A Function</i>	Input Trip (N/O)
7B	<i>Input A Trip</i>	Operating Only
7C	<i>Input A Trip Delay</i>	00:00 (mm:ss)
7D	<i>Input A Initial Delay</i>	00:00 (mm:ss)
7E	<i>Input B Function</i>	Input Trip (N/O)
7F	<i>Input B Trip</i>	Operating Only
7G	<i>Input B Trip Delay</i>	00:00 (mm:ss)
7H	<i>Input B Initial Delay</i>	00:00 (mm:ss)
7I	<i>Reset/Enable Logic</i>	Normally Closed (N/C)
7J	<i>Input A Name</i>	Input A Trip
7K	<i>Input B Name</i>	Input B Trip
<b>8</b>	<b>Relay Outputs</b>	
8A	<i>Relay A Function</i>	Run
8B	<i>Relay A On Delay</i>	00:00 (mm:ss)
8C	<i>Relay A Off Delay</i>	00:00 (mm:ss)
8D	<i>Relay B Function</i>	Run
8E	<i>Relay B On Delay</i>	00:00 (mm:ss)
8F	<i>Relay B Off Delay</i>	00:00 (mm:ss)
8G	<i>Low Current Flag</i>	50%
8H	<i>High Current Flag</i>	100%
8I	<i>Motor Temperature Flag</i>	80%
8J	<i>Main Contactor Time</i>	400 ms
<b>9</b>	<b>Analog Output</b>	
9A	<i>Analog Output A</i>	Current (% FLC)
9B	<i>Analog A Scale</i>	4-20 mA
9C	<i>Analog A Maximum Adjustment</i>	100%
9D	<i>Analog A Minimum Adjustment</i>	000%
<b>10</b>	<b>Display</b>	
10A	<i>Language</i>	English
10B	<i>Temperature Scale</i>	Celsius
10C	<i>Graph Timebase</i>	30 seconds
10D	<i>Graph Maximum Adjustment</i>	400%
10E	<i>Graph Minimum Adjustment</i>	0%
10F	<i>Current Calibration</i>	100%

	<b>Parameter Group</b>	<b>Default Setting</b>
10G	<i>Adjustment Lock</i>	Read & Write
10H	<i>User Parameter 1</i>	Current
10I	<i>User Parameter 2</i>	Motor Voltage
10J	<i>User Parameter 3</i>	Mains Frequency
10K	<i>User Parameter 4</i>	Motor pf
10L	<i>User Parameter 5</i>	Motor Power
10M	<i>User Parameter 6</i>	Motor Temperature (%)
<b>11</b>	<b>Pump Clean</b>	
11A	<i>Reverse Torque</i>	20%
11B	<i>Reverse Time</i>	00:10 (mm:ss)
11C	<i>Forward Current Limit</i>	100%
11D	<i>Forward Time</i>	00:10 (mm:ss)
11E	<i>Pump Stop Mode</i>	Coast To Stop
11F	<i>Pump Stop Time</i>	00:10 (mm:ss)
11G	<i>Pump Clean Cycles</i>	1
<b>12</b>	<b>Communications Card</b>	
12A	<i>Modbus Address</i>	1
12B	<i>Modbus Baud Rate</i>	9600
12C	<i>Modbus Parity</i>	None
12D	<i>Modbus Timeout</i>	Off
12E	<i>Devicenet Address</i>	0
12F	<i>Devicenet Baud Rate</i>	125kB
12G	<i>Profibus Address</i>	1
12H	<i>Gateway Address</i>	192
12I	<i>Gateway Address 2</i>	168
12J	<i>Gateway Address 3</i>	0
12K	<i>Gateway Address 4</i>	100
12L	<i>IP Address</i>	192
12M	<i>IP Address 2</i>	168
12N	<i>IP Address 3</i>	0
12O	<i>IP Address 4</i>	2
12P	<i>Subnet Mask</i>	255
12Q	<i>Subnet Mask 2</i>	255
12R	<i>Subnet Mask 3</i>	255
12S	<i>Subnet Mask 4</i>	0
12T	<i>DHCP</i>	Disable
12U	<i>Location ID</i>	0

	<b>Parameter Group</b>	<b>Default Setting</b>
<b>20</b>	<b>Advanced</b>	
20A	<i>Tracking Gain</i>	50%
20B	<i>Pedestal Detect</i>	80%
20C	<i>Bypass Contactor Delay</i>	100 ms
20D	<i>Model Rating</i>	Model dependent
20E	<i>Screen Timeout</i>	1 minute
20F	<i>Motor Connection</i>	Auto-detect
20G	<i>External Bypass</i>	Disable
20H	<i>Shunt Trip Mode</i>	Disable
<b>30</b>	<b>Pump Input Configuration</b>	
30A	<i>Pressure Sensor Type</i>	None
30B	<i>Pressure Units</i>	kPa
30C	<i>Pressure at 4 mA</i>	0
30D	<i>Pressure at 20 mA</i>	0
30E	<i>Flow Sensor Type</i>	None
30F	<i>Flow Units</i>	litres/second
30G	<i>Flow at 4 mA</i>	0
30H	<i>Flow at 20 mA</i>	0
30I	<i>Units per Minute at Max Flow</i>	0
30J	<i>Pulses per Minute at Max Flow</i>	0
30K	<i>Units per Pulse</i>	0
30L	<i>Depth Sensor Type</i>	None
30M	<i>Depth Units</i>	metres
30N	<i>Depth at 4 mA</i>	0
30O	<i>Depth at 20 mA</i>	0
<b>31</b>	<b>Flow Protection</b>	
31A	<i>High Flow Trip Level</i>	10
31B	<i>Low Flow Trip Level</i>	5
31C	<i>Flow Start Delay</i>	00:00:500 (mm:ss:ms)
31D	<i>Flow Response Delay</i>	00:00:500 (mm:ss:ms)
<b>32</b>	<b>Pressure Protection</b>	
32A	<i>High Pressure Trip Level</i>	10
32B	<i>High Pressure Start Delay</i>	00:00:500 (mm:ss:ms)
32C	<i>High Pressure Response Delay</i>	00:00:500 (mm:ss:ms)
32D	<i>Low Pressure Trip Level</i>	5
32E	<i>Low Pressure Start Delay</i>	00:00:500 (mm:ss:ms)
32F	<i>Low Pressure Response Delay</i>	00:00:500 (mm:ss:ms)

	<b>Parameter Group</b>	<b>Default Setting</b>
<b>33</b>	<b>Pressure Control</b>	
33A	<i>Pressure Control Mode</i>	Off
33B	<i>Start Pressure Level</i>	5
33C	<i>Start Response Delay</i>	00:00:500 (mm:ss:ms)
33D	<i>Stop Pressure Level</i>	10
33E	<i>Stop Response Delay</i>	00:00:500 (mm:ss:ms)
<b>34</b>	<b>Depth Protection</b>	
34A	<i>Depth Trip Level</i>	5
34B	<i>Depth Reset Level</i>	10
34C	<i>Depth Start Delay</i>	00:00:500 (mm:ss:ms)
34D	<i>Depth Response Delay</i>	00:00:500 (mm:ss:ms)
<b>35</b>	<b>Thermal Protection</b>	
35A	<i>Temperature Sensor Type</i>	None
35B	<i>Temperature Trip Level</i>	40
<b>36</b>	<b>Pump Trip Action</b>	
36A	<i>Pressure Sensor</i>	Soft Trip and Log
36B	<i>Flow Sensor</i>	Soft Trip and Log
36C	<i>Depth Sensor</i>	Soft Trip and Log
36D	<i>High Pressure</i>	Soft Trip and Log
36E	<i>Low Pressure</i>	Soft Trip and Log
36F	<i>High Flow</i>	Soft Trip and Log
36G	<i>Low Flow</i>	Soft Trip and Log
36H	<i>Flow Switch</i>	Soft Trip and Log
36I	<i>Well Depth</i>	Soft Trip and Log
36J	<i>RTD/PT100 B</i>	Soft Trip and Log
<b>40</b>	<b>Ground Fault</b>	
40A	<i>Ground Fault Level</i>	0 A
40B	<i>Ground Fault Delay</i>	00:01 (mm:ss)
40D	<i>Ground Fault Trip Active</i>	Operating only
40C	<i>Ground Fault Action</i>	Soft Trip and Log
40E	<i>Ground Fault CT Ratio</i>	1000:1
<b>41</b>	<b>Calibrate 4-20 mA</b>	
41A	<i>4mA Calibration</i>	100%
41B	<i>20mA Calibration</i>	100%

## 1 Motor Details

### 1A – Command Source

---

<b>Options:</b>	Digital Input (default)	The soft starter will accept start and stop commands from the digital inputs.
	Network	The soft starter will accept start and stop commands from the communication expansion card.
	Remote Keypad	The soft starter will accept start and stop commands from the Remote Keypad.
	Clock	The soft starter will start and stop as scheduled in parameters 4D to 4X.
	Smart Card	The soft starter will accept start and stop commands from the smart card.
	Smart Card + Clock	The soft starter will accept start commands from the smart card if they are within the operating schedule set in parameters 4D to 4X. A stop command from the smart card will be accepted regardless of the schedule.
	Timer	After a start signal is received, the soft starter will start and stop the motor according to the timers set in parameters 4B and 4C.

**Description:** Selects the command source for controlling the soft starter.

### 1B – Motor Full Load Current

---

**Range:** Model dependent

**Description:** Matches the starter to the connected motor's full load current. Set to the full load current (FLC) rating shown on the motor nameplate.

### 1C – Motor kW

---

**Range:** 0 - 9999 kW **Default:** 0

**Description:** Sets the running power of the connected motor, in kilowatts. This setting is the basis for power reporting and protection.



#### NOTICE

The motor nameplate may state different power ratings for different supply voltages or power connections. Ensure that the motor kW setting is accurate for the installation.

**1D – Locked Rotor Time**

---

**Range:** 0:01 - 2:00 (minutes:seconds) **Default:** 10 seconds**Description:** Sets the maximum length of time the motor can sustain locked rotor current from cold before reaching its maximum temperature. Set according to the motor datasheet.**1E – Locked Rotor Current**

---

**Range:** 400% - 1200% FLC **Default:** 600%**Description:** Sets the locked rotor current of the connected motor, as a percentage of full load current. Set according to the motor datasheet.**1F – Motor Service Factor**

---

**Range:** 100% - 130% **Default:** 105%**Description:** Sets the motor service factor used by the thermal model. If the motor runs at full load current, it will reach 100%. Set according to the motor datasheet.**NOTICE**

Parameters 1D, 1E and 1F determine the trip current for motor overload protection. The default settings of parameters 1D, 1E and 1F provide Motor Overload Protection: Class 10, Trip Current 105% of FLA (full load amperage) or equivalent.

**1G – Reserved**

---

**Description:** This parameter is reserved for future use.**2 Motor Start/Stop****2A – Start Mode**

---

**Options:** Constant Current (default)  
Adaptive Control**Description:** Selects the soft start mode.**NOTICE**

The soft starter will apply the current limit on all soft starts, including adaptive control. If the current limit is too low or the start ramp time (parameter 2B) is too short, the motor may not start successfully.



**2B – Start Ramp Time**

**Range:** 0:01 - 3:00 (minutes:seconds) **Default:** 10 seconds  
**Description:** Sets the total start time for an Adaptive Control start or the ramp time for current ramp starting (from the initial current to the current limit).

**2C – Initial Current**

**Range:** 100% - 600% FLC **Default:** 200%  
**Description:** Sets the initial start current level for current ramp starting, as a percentage of motor full load current. Set so that the motor begins to accelerate immediately after a start is initiated. If current ramp starting is not required, set the initial current equal to the current limit.

**2D – Current Limit**

**Range:** 100% - 600% FLC **Default:** 350%  
**Description:** Sets the current limit for constant current and current ramp soft starting, as a percentage of motor full load current.

**2E – Adaptive Start Profile**

**Options:** Early Acceleration  
Constant Acceleration (default)  
Late Acceleration  
**Description:** Selects which profile the soft starter will use for an Adaptive Control soft start.

**NOTICE**

The soft starter will apply the current limit on all soft starts, including adaptive control. If the current limit is too low or the start ramp time (parameter 2B) is too short, the motor may not start successfully.

**2F – Kickstart Time**

**Range:** 0 – 2000 milliseconds **Default:** 0000 milliseconds  
**Description:** Sets the kickstart duration. A setting of 0 disables kickstart.

**2G – Kickstart Level**

**Range:** 100% - 700% FLC **Default:** 500%  
**Description:** Sets the level of the kickstart current.

**CAUTION**

Kickstart subjects the mechanical equipment to increased torque levels. Ensure the motor, load and couplings can handle the additional torque before using this feature.

**2H – Jog Torque**

---

The soft starter can jog the motor at a reduced speed, which allows precise positioning of belts and flywheels. Jog can be used for either forward or reverse operation.

**Range:** 20% - 100% **Default:** 50%

**Description:** Sets the current limit for jog operation.

**2I – Stop Mode**

---

**Options:** Coast To Stop DC Brake  
TVR Soft Stop (default) Soft Brake  
Adaptive Control

**Description:** Selects the stop mode.

**2J – Stop Time**

---

**Range:** 0:00 - 4:00 (minutes:seconds) **Default:** 0 second

**Description:** Sets the time for soft stopping the motor using timed voltage ramp or Adaptive Control.

If a main contactor is installed, the contactor must remain closed until the end of the stop time. Use the main contactor output (33, 34) to control the main contactor.

**2K – Adaptive Stop Profile**

---

**Options:** Early Deceleration  
Constant Deceleration (default)  
Late Deceleration

**Description:** Selects which profile the soft starter will use for an Adaptive Control soft stop.

**2L – Adaptive Control Gain**

---

**Range:** 1% - 200% **Default:** 75%

**Description:** Adjusts the performance of Adaptive Control. This setting affects both starting and stopping control.

**2M – Multi Pump**

---

**Options:** Single Pump (default) Manifold Pump

**Description:** Adjusts the performance of adaptive control to suit installations with multiple pumps connected to a common outlet manifold.

**2N – Start Delay**

---

**Range:** 0:00 - 60:00 (minutes:seconds) **Default:** 0 second

**Description:** Sets a delay after the starter receives a start command, before it starts the motor.

**2O – DC Brake Torque**

---

<b>Range:</b>	20% - 100%	<b>Default:</b>	20%
<b>Description:</b>	Sets the amount of brake torque the soft starter will use to slow the motor.		

**2P – DC Brake Time**

---

<b>Range:</b>	0:01 - 0:30 (minutes:seconds)	<b>Default:</b>	1 second
<b>Description:</b>	Sets the duration for DC injection during a braking stop.		

**2Q – Brake Current Limit**

---

<b>Range:</b>	100% - 600% FLC	<b>Default:</b>	250%
<b>Description:</b>	Sets the current limit for soft brake.		

**2R – Soft Brake Delay**

---

<b>Range:</b>	400 - 2000 milliseconds	<b>Default:</b>	400 milliseconds
<b>Description:</b>	Sets the time the soft starter will wait after a stop signal is received, before it begins to supply braking current to the motor. Set to allow time for K1 and K2 to switch.		

EN

**3 Motor Start/Stop-2**

The parameters in this group control the operation of the secondary configuration of the motor. Use the programmable input to select the active motor set.

See *Secondary motor set* on page 68 for details.

**3A – Motor Full Load Current-2**

---

<b>Range:</b>	Model dependent
<b>Description:</b>	Sets the secondary motor's full load current.

**3B – Motor kW-2**

---

<b>Range:</b>	0 - 9999 kW	<b>Default:</b>	0
<b>Description:</b>	Sets the running power of the secondary motor, in kilowatts.		

**3C – Start Mode-2**

---

<b>Options:</b>	Constant Current (default) Adaptive Control
<b>Description:</b>	Selects the soft start mode.

**3D – Start Ramp Time-2**

---

**Range:** 0:01 - 3:00 (minutes:seconds)    **Default:** 10 seconds  
**Description:** Sets the total start time for an Adaptive Control start or the ramp time for current ramp starting (from the initial current to the current limit).

**3E – Initial Current-2**

---

**Range:** 100% - 600% FLC    **Default:** 200%  
**Description:** Sets the initial start current level for current ramp starting, as a percentage of motor full load current. Set so that the motor begins to accelerate immediately after a start is initiated. If current ramp starting is not required, set the initial current equal to the current limit.

**3F – Current Limit-2**

---

**Range:** 100% - 600% FLC    **Default:** 350%  
**Description:** Sets the current limit for constant current and current ramp soft starting, as a percentage of motor full load current.

**NOTICE**

The soft starter will apply the current limit on all soft starts, including adaptive control. If the current limit is too low or the start ramp time (parameter 2B) is too short, the motor may not start successfully.

**3G – Adaptive Start Profile-2**

---

**Options:** Early Acceleration  
Constant Acceleration (default)  
Late Acceleration  
**Description:** Selects which profile the soft starter will use for an Adaptive Control soft start.

**3H – Kickstart Time-2**

---

**Range:** 0 – 2000 milliseconds    **Default:** 0000 milliseconds  
**Description:** Sets the kickstart duration. A setting of 0 disables kickstart.

**3I – Kickstart Level-2**

---

**Range:** 100% - 700% FLC    **Default:** 500%  
**Description:** Sets the level of the kickstart current.

**3J – Jog Torque-2**

---

**Range:** 20% - 100%    **Default:** 50%  
**Description:** Sets the current limit for jog operation.

**3K – Stop Mode-2**

---

<b>Options:</b>	Coast To Stop	TVR Soft Stop (default)
	Adaptive Control	DC Brake
	Soft Brake	

**Description:** Selects the stop mode.

**3L – Stop Time-2**

---

**Range:** 0:00 - 4:00 (minutes:seconds) **Default:** 0 second

**Description:** Sets the time for soft stopping the motor using timed voltage ramp or Adaptive Control.

If a main contactor is installed, the contactor must remain closed until the end of the stop time. Use the main contactor output (33, 34) to control the main contactor.

**3M – Adaptive Stop Profile-2**

---

<b>Options:</b>	Early Deceleration
	Constant Deceleration (default)
	Late Deceleration

**Description:** Selects which profile the soft starter will use for an Adaptive Control soft stop.

**3N – Adaptive Control Gain-2**

---

**Range:** 1%~200% **Default:** 75%

**Description:** Adjusts the performance of Adaptive Control. This setting affects both starting and stopping control.

**3O – Multi Pump-2**

---

<b>Options:</b>	Single Pump (default)	Manifold Pump
-----------------	-----------------------	---------------

**Description:** Adjusts the performance of adaptive control to suit installations with multiple pumps connected to a common outlet manifold.

**3P – Start Delay-2**

---

**Range:** 0:00 - 60:00 (minutes:seconds) **Default:** 0 second

**Description:** Sets a delay after the starter receives a start command, before it starts the motor.

**3Q – DC Brake Torque-2**

---

**Range:** 20% - 100% **Default:** 20%

**Description:** Sets the amount of brake torque the soft starter will use to slow the motor.

**3R – DC Brake Time-2**

---

**Range:** 0:01 - 0:30 (minutes:seconds)    **Default:** 1 second

**Description:** Sets the duration for DC injection during a braking stop.

**3S – Brake Current Limit-2**

---

**Range:** 100% - 600% FLC    **Default:** 250%

**Description:** Sets the current limit for soft brake.

**3T – Soft Brake Delay-2**

---

**Range:** 400 - 2000 milliseconds    **Default:** 400 milliseconds

**Description:** Sets the time the soft starter will wait after a stop signal is received, before it begins to supply braking current to the motor. Set to allow time for K1 and K2 to switch.

**4 Auto-Start/Stop**

The starter can be configured to automatically start and/or stop the motor at a particular time, or run it in cycles of a specified duration.

**4A – Auto-Start/Stop Mode**

---

**Options:**    Disable (default)  
                   Enable Clock Mode  
                   Enable Timer Mode

**Description:** Enable or disable auto-start/stop operation.

**4B – Run Time**

---

**Range:** 00:00 - 23:59 hh:mm    **Default:** 00:00

**Description:** Sets the duration for the starter to run, after a timer mode auto-start.

**4C – Stopped Time**

---

**Range:** 00:00 - 23:59 hh:mm    **Default:** 00:00

**Description:** Sets the duration for the starter to remain stopped, when operating in timer mode.

**4D – Sunday Mode**

---

**Options:**    Start/Stop Disable    Disables auto-start/stop control. Any times (default) scheduled in parameters 4E or 4F will be ignored.  
                   Start Only Enable    Enables auto-start control. Any auto-stop times scheduled in parameter 4F will be ignored.  
                   Stop Only Enable    Enables auto-stop control. Any auto-start times scheduled in parameter 4E will be ignored.  
                   Start/Stop Enable    Enables auto-start and auto-stop control.

**Description:** Enables or disables auto-start/stop for Sunday.

#### **4E – Sunday Start Time**

**Range:** 00:00 - 23:59 **Default:** 00:00

**Description:** Sets the auto-start time for Sunday (24 hour format).

#### **4F – Sunday Stop Time**

**Range:** 00:00 - 23:59 **Default:** 00:00

**Description:** Sets the auto-stop time for Sunday (24 hour format).

#### **4G – Monday Mode**

**Options:** Start/Stop Disable (default) Stop Only Enable  
Start Only Enable Start/Stop Enable

**Description:** Enables or disables auto-start/stop for Monday.

#### **4H – Monday Start Time**

**Range:** 00:00 - 23:59 **Default:** 00:00

**Description:** Sets the auto-start time for Monday (24 hour format).

#### **4I – Monday Stop Time**

**Range:** 00:00 - 23:59 **Default:** 00:00

**Description:** Sets the auto-stop time for Monday (24 hour format).

#### **4J – Tuesday Mode**

**Options:** Start/Stop Disable (default) Stop Only Enable  
Start Only Enable Start/Stop Enable

**Description:** Enables or disables auto-start/stop for Tuesday.

#### **4K – Tuesday Start Time**

**Range:** 00:00 - 23:59 **Default:** 00:00

**Description:** Sets the auto-start time for Tuesday (24 hour format).

#### **4L – Tuesday Stop Time**

**Range:** 00:00 - 23:59 **Default:** 00:00

**Description:** Sets the auto-stop time for Tuesday (24 hour format).

#### **4M – Wednesday Mode**

**Options:** Start/Stop Disable (default) Stop Only Enable  
Start Only Enable Start/Stop Enable

**Description:** Enables or disables auto-start/stop for Wednesday.

**4N – Wednesday Start Time**

---

<b>Range:</b>	00:00 - 23:59	<b>Default:</b>	00:00
---------------	---------------	-----------------	-------

**Description:** Sets the auto-start time for Wednesday (24 hour format).

**4O – Wednesday Stop Time**

---

<b>Range:</b>	00:00 - 23:59	<b>Default:</b>	00:00
---------------	---------------	-----------------	-------

**Description:** Sets the auto-stop time for Wednesday (24 hour format).

**4P – Thursday Mode**

---

<b>Options:</b>	Start/Stop Disable (default)	Stop Only Enable
	Start Only Enable	Start/Stop Enable

**Description:** Enables or disables auto-start/stop for Thursday.

**4Q – Thursday Start Time**

---

<b>Range:</b>	00:00 - 23:59	<b>Default:</b>	00:00
---------------	---------------	-----------------	-------

**Description:** Sets the auto-start time for Thursday (24 hour format).

**4R – Thursday Stop Time**

---

<b>Range:</b>	00:00 - 23:59	<b>Default:</b>	00:00
---------------	---------------	-----------------	-------

**Description:** Sets the auto-stop time for Thursday (24 hour format).

**4S – Friday Mode**

---

<b>Options:</b>	Start/Stop Disable (default)	Stop Only Enable
	Start Only Enable	Start/Stop Enable

**Description:** Enables or disables auto-start/stop for Friday.

**4T – Friday Start Time**

---

<b>Range:</b>	00:00 - 23:59	<b>Default:</b>	00:00
---------------	---------------	-----------------	-------

**Description:** Sets the auto-start time for Friday (24 hour format).

**4U – Friday Stop Time**

---

<b>Range:</b>	00:00 - 23:59	<b>Default:</b>	00:00
---------------	---------------	-----------------	-------

**Description:** Sets the auto-stop time for Friday (24 hour format).

**4V – Saturday Mode**

---

<b>Options:</b>	Start/Stop Disable (default)	Stop Only Enable
	Start Only Enable	Start/Stop Enable

**Description:** Enables or disables auto-start/stop for Saturday.

**4W – Saturday Start Time**

---

<b>Range:</b>	00:00 - 23:59	<b>Default:</b>	00:00
---------------	---------------	-----------------	-------

**Description:** Sets the auto-start time for Saturday (24 hour format).



**4X – Saturday Stop Time**

---

**Range:** 00:00 - 23:59 **Default:** 00:00

**Description:** Sets the auto-stop time for Saturday (24 hour format).

**5 Protection Levels****5A – Current Imbalance**

---

**Range:** 10% - 50% **Default:** 30%

**Description:** Sets the trip point for current imbalance protection.

**5B – Current Imbalance Delay**

---

**Range:** 0:00 - 4:00 (minutes:seconds) **Default:** 3 seconds

**Description:** Slows the soft starter's response to current imbalance, avoiding trips due to momentary fluctuations.

**5C – Undercurrent**

---

**Range:** 0% - 100% **Default:** 20%

**Description:** Sets the trip point for undercurrent protection, as a percentage of motor full load current. Set to a level between the motor's normal working range and the motor's magnetising (no load) current (typically 25% to 35% of full load current). A setting of 0% disables undercurrent protection.

**5D – Undercurrent Delay**

---

**Range:** 0:00 - 4:00 (minutes:seconds) **Default:** 5 seconds

**Description:** Slows the soft starter's response to undercurrent, avoiding trips due to momentary fluctuations.

**5E – Overcurrent**

---

**Range:** 80% - 600% **Default:** 400%

**Description:** Sets the trip point for overcurrent protection, as a percentage of motor full load current.

**5F – Overcurrent Delay**

---

**Range:** 0:00 - 1:00 (minutes:seconds) **Default:** 0 second

**Description:** Slows the soft starter's response to overcurrent, avoiding trips due to momentary overcurrent events.

EN

**5G – Undervoltage**

---

**Range:** 100 - 1200 V **Default:** 350

**Description:** Sets the trip point for undervoltage protection. Set as required.

**NOTICE**

Voltage protections will not operate correctly until the starter is in Run mode.

**5H – Undervoltage Delay**

---

**Range:** 0:00 - 1:00 (minutes:seconds) **Default:** 1 second

**Description:** Slows the soft starter's response to undervoltage, avoiding trips due to momentary fluctuations.

**5I – Overvoltage**

---

**Range:** 100 - 1500 V **Default:** 500

**Description:** Sets the trip point for overvoltage protection. Set as required.

**5J – Overvoltage Delay**

---

**Range:** 0:00 - 1:00 (minutes:seconds) **Default:** 1 second

**Description:** Slows the soft starter's response to overvoltage, avoiding trips due to momentary fluctuations.

**5K – Underpower**

---

**Range:** 10% -120% **Default:** 10%

**Description:** Sets the trip point for underpower protection. Set as required.

**5L – Underpower Delay**

---

**Range:** 0:01 - 1:00 (minutes:seconds) **Default:** 5 seconds

**Description:** Slows the soft starter's response to underpower, avoiding trips due to momentary fluctuations.

**5M – Overpower**

---

**Range:** 80% -200% **Default:** 150%

**Description:** Sets the trip point for overpower protection. Set as required.

**5N – Overpower Delay**

---

**Range:** 0:01 - 1:00 (minutes:seconds) **Default:** 5 seconds

**Description:** Slows the soft starter's response to overpower, avoiding trips due to momentary fluctuations.

**5O – Excess Start Time**

**Range:** 0:00 - 4:00 (minutes:seconds) **Default:** 20 seconds

**Description:** Excess start time is the maximum time the soft starter will attempt to start the motor. If the motor does not transition to Run mode within the programmed limit, the starter will trip. Set for a period slightly longer than required for a normal healthy start. A setting of 0 disables excess start time protection.

**5P – Restart Delay**

**Range:** 00:01 - 60:00 (minutes:seconds) **Default:** 10 seconds

**Description:** The soft starter can be configured to force a delay between the end of a stop and the beginning of the next start. During the restart delay period, the display shows the time remaining before another start can be attempted.

**5Q – Starts per Hour**

**Range:** 0 - 10 **Default:** 0

**Description:** Sets the maximum number of starts the soft starter will attempt in a 60 minute period. A setting of 0 disables this protection.

**5R – Phase Sequence**

**Options:** Any Sequence (default)  
Positive Only  
Negative Only

**Description:** Selects which phase sequences the soft starter will allow at a start. During its pre-start checks, the starter examines the sequence of the phases at its input terminals and trips if the actual sequence does not match the selected option.

**CAUTION**

When using DC brake, the mains supply must be connected to the soft starter (input terminals L1, L2, L3) in positive phase sequence and parameter 5R *Phase Sequence* must be set to Positive Only.

**6 Protection Action****6A – Auto-Reset Count**

**Range:** 0 – 5 **Default:** 0

**Description:** Sets how many times the soft starter will auto-reset, if it continues to trip.

The reset counter increases by one each time the soft starter auto-resets, and resets after a successful start.

Setting this parameter to zero disables auto-reset.

**6B – Auto-Reset Delay**

---

**Range:** 0:05 - 15:00 (minutes:seconds) **Default:** 5 seconds

**Description:** Sets a delay before the soft starter will auto-reset a trip.

**6C – Current Imbalance**

---

<b>Options:</b>	Soft Trip and Log (default)	The soft starter will stop the motor as selected in parameter 2I or 3K <i>Stop Mode</i> , then enter trip state. The trip must be reset before the starter can restart.
	Soft Trip and Reset	The soft starter will stop the motor as selected in parameter 2I or 3K <i>Stop Mode</i> , then enter trip state. The trip will reset after the auto-reset delay.
	Trip Starter	The soft starter will remove power and the motor will coast to stop. The trip must be reset before the starter can restart.
	Trip and Reset	The soft starter will remove power and the motor will coast to stop. The trip will reset after the auto-reset delay.
	Warn and Log	The protection will be written to the event log and the display will show a warning message, but the soft starter will continue to operate.
	Log Only	The protection will be written to the event log but the soft starter will continue to operate.
	Trip + Shunt Relay	The soft starter will remove power and the motor will coast to stop. The shunt trip relay (33, 34) will activate and the circuit breaker will disconnect mains voltage from the soft starter. The circuit breaker must be manually reset before operation can resume. This option is only effective if parameter 20H <i>Shunt Trip Mode</i> is set to 'Enable'.

**Description:** Selects the soft starter's response to each protection. All protection events are written to the event log.

**6D – Undercurrent**

---

<b>Options:</b>	Soft Trip and Log (default)	Warn and Log
	Soft Trip and Reset	Log Only
	Trip Starter	Trip + Shunt Relay
	Trip and Reset	

**Description:** Selects the soft starter's response to the protection event.

**6E – Overcurrent**

---

<b>Options:</b>	Soft Trip and Log (default)	Warn and Log
	Soft Trip and Reset	Log Only

Trip Starter	Trip + Shunt Relay
Trip and Reset	

**Description:** Selects the soft starter's response to the protection event.

### 6F – Undervoltage

---

<b>Options:</b>	Soft Trip and Log (default)	Warn and Log
	Soft Trip and Reset	Log Only
	Trip Starter	Trip + Shunt Relay
	Trip and Reset	

**Description:** Selects the soft starter's response to the protection event.

### 6G – Overvoltage

---

<b>Options:</b>	Soft Trip and Log (default)	Warn and Log
	Soft Trip and Reset	Log Only
	Trip Starter	Trip + Shunt Relay
	Trip and Reset	

**Description:** Selects the soft starter's response to the protection event.

### 6H – Underpower

---

<b>Options:</b>	Log Only (default)	Trip Starter
	Trip + Shunt Relay	Trip and Reset
	Soft Trip and Log	Warn and Log
	Soft Trip and Reset	

**Description:** Selects the soft starter's response to the protection event.

### 6I – Overpower

---

<b>Options:</b>	Log Only (default)	Trip Starter
	Trip + Shunt Relay	Trip and Reset
	Soft Trip and Log	Warn and Log
	Soft Trip and Reset	

**Description:** Selects the soft starter's response to the protection event.

### 6J – Excess Start Time

---

<b>Options:</b>	Soft Trip and Log (default)	Warn and Log
	Soft Trip and Reset	Log Only
	Trip Starter	Trip + Shunt Relay
	Trip and Reset	

**Description:** Selects the soft starter's response to the protection event.

**6K – Input A Trip**

---

<b>Options:</b>	Soft Trip and Log (default)	Warn and Log
	Soft Trip and Reset	Log Only
	Trip Starter	Trip + Shunt Relay
	Trip and Reset	

**Description:** Selects the soft starter's response to the protection event.

**6L – Input B Trip**

---

<b>Options:</b>	Soft Trip and Log (default)	Warn and Log
	Soft Trip and Reset	Log Only
	Trip Starter	Trip + Shunt Relay
	Trip and Reset	

**Description:** Selects the soft starter's response to the protection event.

**6M – Network Communications**

---

<b>Options:</b>	Soft Trip and Log (default)	Warn and Log
	Soft Trip and Reset	Log Only
	Trip Starter	Stop
	Trip and Reset	Trip + Shunt Relay

**Description:** Selects the soft starter's response to the protection event. If set to Stop, the soft starter will perform a soft stop, then can be restarted without a reset.

**6N – Remote Keypad Fault**

---

<b>Options:</b>	Soft Trip and Log (default)	Warn and Log
	Soft Trip and Reset	Log Only
	Trip Starter	Trip + Shunt Relay
	Trip and Reset	

**Description:** Selects the soft starter's response to the protection event.

**6O – Frequency**

---

<b>Options:</b>	Soft Trip and Log (default)	Warn and Log
	Soft Trip and Reset	Log Only
	Trip Starter	Trip + Shunt Relay
	Trip and Reset	

**Description:** Selects the soft starter's response to the protection event.

**6P – Phase Sequence**

---

<b>Options:</b>	Soft Trip and Log (default)	Warn and Log
	Soft Trip and Reset	Log Only

Trip Starter	Trip + Shunt Relay
Trip and Reset	

**Description:** Selects the soft starter's response to the protection event.

#### 6Q – *Motor Overtemperature*

---

<b>Options:</b>	Soft Trip and Log (default)	Warn and Log
	Soft Trip and Reset	Log Only
	Trip Starter	Trip + Shunt Relay
	Trip and Reset	

**Description:** Selects the soft starter's response to the protection event.

#### 6R – *Motor Thermistor Circuit*

---

<b>Options:</b>	Soft Trip and Log (default)	Warn and Log
	Soft Trip and Reset	Log Only
	Trip Starter	Trip + Shunt Relay
	Trip and Reset	

**Description:** Selects the soft starter's response to the protection event.

#### 6S – *Shorted SCR Action*

---

**Options:** 3-Phase Control Only (default)  
PowerThrough  
Trip + Shunt Relay

**Description:** Selects whether the soft starter will allow PowerThrough operation, if the soft starter is damaged on one phase. The soft starter will use two-phase control, allowing the motor to continue operating in critical applications. See *PowerThrough* on page 54 for further information.

#### 6T – *Battery/Clock*

---

<b>Options:</b>	Soft Trip and Log (default)	Warn and Log
	Soft Trip and Reset	Log Only
	Trip Starter	Trip + Shunt Relay
	Trip and Reset	

**Description:** Selects the soft starter's response to the protection event.

## 7 Inputs

### 7A – Input A Function

---

<b>Options:</b>	Command Override: Network	Overrides the setting of 1A and sets the command source to the communications network.
	Command Override: Digital	Overrides the setting of 1A and sets the command source to the digital inputs.
	Command Override: Keypad	Overrides the setting of 1A and sets the command source to the remote keypad.
	Input Trip (N/O) (default)	A closed circuit across 13, 14 trips the soft starter.
	Input Trip (N/C)	An open circuit across 13, 14 trips the soft starter.
	Emergency Mode	A closed circuit across 13, 14 activates emergency mode. When the soft starter receives a start command, it will continue to run until a stop command is received, ignoring all trips and warnings.
	Jog Forward	Activates jog operation in a forward direction.
	Jog Reverse	Activates jog operation in reverse direction.
	Zero Speed Sensor	An open circuit across 13, 14 indicates to the soft starter that the motor has reached a standstill. The soft starter requires a normally open zero speed sensor.
	Motor Set Select	A closed circuit across 13, 14 instructs the starter to use the secondary motor configuration for the next start/stop cycle.
	Reverse Direction	A closed circuit across 13, 14 instructs the starter to reverse the phase sequence for the next start.
	Pump Clean	Activates the pump clean function.

**Description:** Selects the function of Input A.

### 7B – Input A Trip

---

<b>Options:</b>	Always Active	A trip can occur at any time when the soft starter is receiving power.
	Operating (default)	A trip can occur while the soft starter is running, stopping or starting.
	Run Only	A trip can only occur while the soft starter is running.

**Description:** Selects when an input trip can occur.



**7C – Input A Trip Delay**

---

**Range:** 0:00 - 4:00 (minutes:seconds)    **Default:** 0 second

**Description:** Sets a delay between the input activating and the soft starter tripping.

**7D – Input A Initial Delay**

---

**Range:** 00:00 - 30:00 (minutes:seconds)    **Default:** 0 second

**Description:** Sets a delay before an input trip can occur. The initial delay is counted from the time a start command is received. The state of the input is ignored until the initial delay has elapsed.

**7E – Input B Function**

---

<b>Options:</b>	Input Trip (N/O) (default)	Zero Speed Sensor
	Input Trip (N/C)	Motor Set Select
	Emergency Mode	Reverse Direction
	Jog Forward	Pump Clean
	Jog Reverse	

**Description:** Selects the function of Input B. See parameter 7A *Input A Function* for details.

**7F – Input B Trip**

---

<b>Options:</b>	Always Active	Operating Only (default)
	Run Only	

**Description:** Selects when an input trip can occur.

**7G – Input B Trip Delay**

---

**Range:** 0:00 - 4:00 (minutes:seconds)    **Default:** 0 second

**Description:** Sets a delay between the input activating and the soft starter tripping.

**7H – Input B Initial Delay**

---

**Range:** 00:00 - 30:00 (minutes:seconds)    **Default:** 0 second

**Description:** Sets a delay before an input trip can occur. The initial delay is counted from the time a start command is received. The state of the input is ignored until the initial delay has elapsed.

**7I – Reset/Enable Logic**

---

**Options:** Normally Closed (default)  
Normally Open

**Description:** Selects whether the reset input (10, 11) is normally open or normally closed.

**NOTICE**

If the reset input is active, the starter will not operate.

**7J – Input A Name**

---

<b>Options:</b>	Input A Trip (default)	Controller
	Low Pressure	PLC
	High Pressure	Vibration Alarm
	Pump Fault	Field Trip
	Low Level	Interlock Trip
	High Level	Motor Temperature
	No Flow	Motor Protection
	Starter Disable	Feeder Protection
		Custom Message

**Description:** Selects a message for the keypad to display when Input A is active.

The custom message can be loaded via the USB port. See *USB Save & Load* on page 41 for details.

**7K – Input B Name**

---

<b>Options:</b>	Input B Trip (default)	Controller
	Low Pressure	PLC
	High Pressure	Vibration Alarm
	Pump Fault	Field Trip
	Low Level	Interlock Trip
	High Level	Motor Temperature
	No Flow	Motor Protection
	Starter Disable	Feeder Protection
		Custom Message

**Description:** Selects a message for the keypad to display when Input B is active.

**8 Relay Outputs****8A – Relay A Function**

---

<b>Options:</b>	Off	Relay A is not used.
	Ready	The relay is closed when the starter is in Ready state.

Run (default)	The Run output closes when the soft start is complete (when the starting current falls below 120% of the programmed motor full load current) and remains closed until the beginning of a stop (either soft stop or coast to stop).
Warning	The relay closes when the starter issues a warning (see 6 <i>Protection Action</i> on page 89).
Trip	The relay closes when the starter trips (see 6 <i>Protection Action</i> on page 89).
Low Current Flag	The relay closes when the low current flag activates while the motor is running (see parameter 8G <i>Low Current Flag</i> ).
High Current Flag	The relay closes when the high current flag activates while the motor is running (see parameter 8H <i>High Current Flag</i> ).
Motor Temperature Flag	The relay closes when the motor temperature flag activates (see parameter 8I <i>Motor Temperature Flag</i> ).
Soft Brake Relay	The relay closes when the soft starter receives a stop signal, and remains closed until the end of soft brake.
Reversing Contactor	The relay will control an external contactor, for reverse operation. See <i>Reverse direction operation</i> on page 65 for details.
Trip Failsafe	The relay closes when control power is applied. The relay opens if the soft starter trips or if control power is lost.
Operating Only	The relay is closed while the soft starter is running, stopping or starting.

**Description:** Selects the function of Relay A. Relay A is a changeover relay.

### 8B – Relay A On Delay

**Range:** 0:00 - 5:00 (minutes:seconds) **Default:** 0 second

**Description:** Sets the delay for changing the state of Relay A.

### 8C – Relay A Off Delay

**Range:** 0:00 - 5:00 (minutes:seconds) **Default:** 0 second

**Description:** Sets the delay for changing the state of Relay A.

### 8D – Relay B Function

<b>Options:</b>	Off	High Current Flag
	Ready	Motor Temperature Flag
	Run (default)	Soft Brake Relay
	Warning	Reversing Contactor

Trip	Trip Failsafe
Low Current Flag	Operating Only

**Description:** Selects the function of Relay B (normally open). See parameter 8A *Relay A Function*.

#### **8E – Relay B On Delay**

**Range:** 0:00 - 5:00 (minutes:seconds) **Default:** 0 second

**Description:** Sets the delay for closing Relay B.

#### **8F – Relay B Off Delay**

**Range:** 0:00 - 5:00 (minutes:seconds) **Default:** 0 second

**Description:** Sets the delay for re-opening Relay B.

#### **8G – Low Current Flag**

The soft starter has low and high current flags to give early warning of abnormal operation. The current flags can be configured to indicate an abnormal current level during operation, between the normal operating level and the undercurrent or instantaneous overcurrent trip levels. The flags can signal the situation to external equipment via one of the programmable outputs.

The flags clear when the current returns within the normal operating range by 10% of the programmed flag value.

**Range:** 1% - 100% FLC **Default:** 50%

**Description:** Sets the level at which the low current flag operates, as a percentage of motor full load current.

#### **8H – High Current Flag**

**Range:** 50% - 600% FLC **Default:** 100%

**Description:** Sets the level at which the high current flag operates, as a percentage of motor full load current.

#### **8I – Motor Temperature Flag**

The soft starter has a motor temperature flag to give early warning of abnormal operation. The flag can indicate that the motor is operating above its normal operating temperature but lower than the overload limit. The flag can signal the situation to external equipment via one of the programmable outputs.

**Range:** 0% - 160% **Default:** 80%

**Description:** Sets the level at which the motor temperature flag operates, as a percentage of the motor's thermal capacity.

#### **8J – Main Contactor Time**

**Range:** 100 – 2000 milliseconds **Default:** 400 milliseconds

**Description:** Sets the delay period between the starter switching the main contactor output (terminals 33, 34) and beginning the pre-start checks (before a start) or entering the not ready state (after a stop). Set according to the specifications of the main contactor used.

## 9 Analog Output

### 9A – Analog Output A

<b>Options:</b>	Current (% FLC) (default)	Current as a percentage of motor full load current.
	Motor Temperature (%)	The motor's temperature, calculated by the thermal model.
	Motor pf	Motor power factor, measured by the soft starter.
	Motor Power (%kW)	Motor power, as a percentage of the programmed power.
	Heatsink Temperature (%)	The soft starter's temperature, as a percentage of the heatsink's maximum allowed operating temperature.

**Description:** Selects which information will be reported via the analog output.

### 9B – Analog A Scale

**Range:** 0-20 mA  
4-20 mA (default)

**Description:** Selects the range of the analog output.

### 9C – Analog A Maximum Adjustment

**Range:** 0% - 600%                      **Default:** 100%

**Description:** Sets the upper limit of the range that the analog output will represent. When the selected information is at or above the upper limit, the analog output will remain at its highest value.

### 9D – Analog A Minimum Adjustment

**Range:** 0% - 600%                      **Default:** 0%

**Description:** Sets the lower limit of the range that the analog output will represent. When the selected information is at or below the lower limit, the analog output will remain at its lowest value.

**NOTICE**

If the values of parameters 9C and 9D are far apart, the analog output will represent a wide dynamic range. The resolution of the output will be coarse.

**NOTICE**

Use parameters 41A *4 mA Calibration* and 41B *20 mA Calibration* to calibrate the analog output.

## 10 Display

### 10A – *Language*

---

<b>Options:</b>	English (default)	Português
	Chinese	Français
	Español	Italiano
	Deutsch	Russian

**Description:** Selects which language the keypad will use to display messages and feedback.

### 10B – *Temperature Scale*

---

<b>Options:</b>	Celsius (default)
	Fahrenheit

**Description:** Selects whether the soft starter will display temperatures in degrees Celsius or Fahrenheit.

### 10C – *Graph Timebase*

---

<b>Options:</b>	30 seconds (default)	30 minutes
	1 minute	1 hour

**Description:** Sets the graph time scale. The graph will progressively replace the old data with new data.

### 10D – *Graph Maximum Adjustment*

---

<b>Range:</b>	0% – 600%	<b>Default:</b>	400%
---------------	-----------	-----------------	------

**Description:** Adjusts the upper limit of the performance graph.

### 10E – *Graph Minimum Adjustment*

---

<b>Range:</b>	0% – 600%	<b>Default:</b>	0%
---------------	-----------	-----------------	----

**Description:** Adjusts the lower limit of the performance graph.

**10F – Current Calibration**

**Range:** 85% - 115% **Default:** 100%

**Description:** Calibrates the soft starter's current monitoring circuits to match an external current metering device. Use the following formula to determine the necessary adjustment:

$$\text{Calibration (\%)} = \frac{\text{Current shown on soft starter display}}{\text{Current measured by external device}}$$

**10G – Adjustment Lock**

**Options:** Read & Write (default) Allows users to alter parameter values in the main menu.  
Read Only Prevents users altering parameter values in the main menu. Parameter values can still be viewed.

**Description:** Selects whether the keypad will allow parameters to be changed via the main menu.

**10H – User Parameter 1**

<b>Options:</b>	Blank	Displays no data in the selected area, allowing long messages to be shown without overlapping.
	Current (default)	Average rms current across all three phases
	Motor Voltage	Average rms voltage across all three phases.
	P1 Voltage	Phase 1 voltage.
	P2 Voltage	Phase 2 voltage.
	P3 Voltage	Phase 3 voltage.
	Mains Frequency	The average frequency measured on three phases.
	Motor pf	The motor's power factor, measured by the soft starter.
	Motor Power	The motor's running power in kilowatts.
	Motor Temperature (%)	The motor's temperature, calculated by the thermal model.
	Hours Run	The number of hours the motor has run via the soft starter.
	Number of Starts	The number of starts the soft starter has completed since the start counter was last reset.
	Pump Pressure	The pressure at the pump, as configured in parameters 30B~30D. This information is only available if the smart card is installed.

Pump Flow	The flow at the pump, as configured in parameters 30F~30K. This information is only available if the smart card is installed.
Well Depth	The depth of the well, as configured in parameters 30M~30O. This information is only available if the smart card is installed.
Pump Temperature	The pump temperature, as measured by the PT100. This information is only available if the smart card is installed.
Analog Output Value	The value of the analog output (see parameters 9A~9D).
Heatsink Temperature	The soft starter's temperature, measured at the heatsink.
Bypass Model (%)	The percentage of thermal capacity remaining in the bypass contactor.
SCR Temperature	The temperature of the SCRs, calculated by the thermal model.
Rating Capacity (%)	The thermal capacity available in the soft starter for its next start.

**Description:** Selects which information will be displayed on the main monitoring screen.

### 10I – User Parameter 2

**Options:** See parameter 10H **Default:** Motor Voltage  
*User Parameter 1* for details.

**Description:** Selects which information will be displayed on the main monitoring screen. See parameter 10H *User Parameter 1* for details.

### 10J – User Parameter 3

<b>Options:</b>	Blank	Number of Starts
	Current (default)	Pump Pressure
	Motor Voltage	Pump Flow
	P1 Voltage	Well Depth
	P2 Voltage	Pump Temperature
	P3 Voltage	Analog Output Value
	Mains Frequency (default)	Heatsink Temperature
	Motor pf	Bypass Model (%)
	Motor Power	SCR Temperature
	Motor Temperature (%)	Rating Capacity (%)
	Hours Run	Ground Fault



**Description:** Selects which information will be displayed on the programmable monitoring screen.

#### 10K – User Parameter 4

**Options:** See parameter 10J **Default:** Motor pf  
*User Parameter 3 for details.*

**Description:** Selects which information will be displayed on the programmable monitoring screen.

#### 10L – User Parameter 5

**Options:** See parameter 10J **Default:** Motor Power  
*User Parameter 3 for details.*

**Description:** Selects which information will be displayed on the programmable monitoring screen.

#### 10M – User Parameter 6

**Options:** See parameter 10J **Default:** Motor Temperature (%)  
*User Parameter 3 for details.*

**Description:** Selects which information will be displayed on the programmable monitoring screen.

## 11 Pump Clean

#### 11A – Reverse Torque

**Range:** 20% - 100% **Default:** 20%

**Description:** Sets the torque level for reverse jog operation during pump clean.

#### 11B – Reverse Time

**Range:** 0:00 - 1:00 (minutes:seconds) **Default:** 10 seconds

**Description:** Sets the time for the starter to operate in reverse jog during a pump clean cycle.

#### 11C – Forward Current Limit

**Range:** 100% - 600% FLC **Default:** 100%

**Description:** Sets the current limit for forward start operation during pump clean.

#### 11D – Forward Time

**Range:** 0:00 - 1:00 (minutes:seconds) **Default:** 10 seconds

**Description:** Sets the time for the starter to run the motor after a forward start, during a pump clean cycle.

**11E – Pump Stop Mode**

---

**Options:** Coast To Stop (default)  
TVR Soft Stop

**Description:** Selects the stop mode for pump clean.

**11F – Pump Stop Time**

---

**Range:** 0:00 - 1:00 (minutes:seconds) **Default:** 10 seconds

**Description:** Sets the stopping time for the starter during a pump clean cycle.

**11G – Pump Clean Cycles**

---

**Range:** 1 – 5 **Default:** 1

**Description:** Sets how many times the soft starter will repeat the pump clean cycle.

**12 Communications Card****12A – Modbus Address**

---

**Range:** 1 - 254 **Default:** 1

**Description:** Sets the Modbus RTU network address for the soft starter.

**12B – Modbus Baud Rate**

---

**Options:** 4800 19200  
9600 (default) 38400

**Description:** Selects the baud rate for Modbus RTU communications.

**12C – Modbus Parity**

---

**Options:** None (default) Even  
Odd 10-bit

**Description:** Selects the parity for Modbus RTU communications.

**12D – Modbus Timeout**

---

**Options:** Off (default) 60 seconds  
10 seconds 100 seconds

**Description:** Selects the timeout for Modbus RTU communications.

**12E – Devicenet Address**

---

**Range:** 0 - 63 **Default:** 0

**Description:** Sets the DeviceNet network address for the soft starter.

**12F – Devicenet Baud Rate**

**Options:** 125 kB (default)  
250 kB  
500 kB

**Description:** Selects the baud rate for DeviceNet communications.

**12G – Profibus Address**

**Range:** 1 - 125 **Default:** 1

**Description:** Sets the Profibus network address for the soft starter.

**12H – Gateway Address**

**Range:** 0 - 255 **Default:** 192

**Description:** Sets the first component of the network gateway address. The gateway address is set using parameters 12H~12K and the default address is 192.168.0.100.

**12I – Gateway Address 2**

**Range:** 0 - 255 **Default:** 168

**Description:** Sets the second component of the network gateway address.

**12J – Gateway Address 3**

**Range:** 0 - 255 **Default:** 0

**Description:** Sets the third component of the network gateway address.

**12K – Gateway Address 4**

**Range:** 0 - 255 **Default:** 100

**Description:** Sets the fourth component of the network gateway address.

**NOTICE**

The network address can also be set via the Network Address options in the Setup Tools. See *Network Address* on page 43 for details.

**12L – IP Address**

**Range:** 0 - 255 **Default:** 192

**Description:** Sets the first component of the soft starter's IP address, for Ethernet communications. The IP address is set using parameters 12L~12O and the default address is 192.168.0.2.

**12M – IP Address 2**

**Range:** 0 - 255 **Default:** 168

**Description:** Sets the second component of the soft starter's IP address, for Ethernet communications.

**12N – IP Address 3**

---

**Range:** 0 - 255 **Default:** 0  
**Description:** Sets the third component of the soft starter's IP address, for Ethernet communications.

**12O – IP Address 4**

---

**Range:** 0 - 255 **Default:** 2  
**Description:** Sets the fourth component of the soft starter's IP address, for Ethernet communications.

**NOTICE**

The network address can also be set via the Network Address options in the Setup Tools. See *Network Address* on page 43 for details.

**12P – Subnet Mask**

---

**Range:** 0 - 255 **Default:** 255  
**Description:** Sets the first component of the network subnet mask, for Ethernet communications. The subnet mask is set using parameters 12P~12S and the default mask is 255.255.255.0.

**12Q – Subnet Mask 2**

---

**Range:** 0 - 255 **Default:** 255  
**Description:** Sets the second component of the network subnet mask, for Ethernet communications.

**12R – Subnet Mask 3**

---

**Range:** 0 - 255 **Default:** 255  
**Description:** Sets the third component of the network subnet mask, for Ethernet communications.

**12S – Subnet Mask 4**

---

**Range:** 0 - 255 **Default:** 0  
**Description:** Sets the fourth component of the network subnet mask, for Ethernet communications.

**NOTICE**

The network address can also be set via the Network Address options in the Setup Tools. See *Network Address* on page 43 for details.

**12T – DHCP**

---

**Options:** Disable (default)  
 Enable  
**Description:** Selects whether the communications card will accept an IP address assigned by DHCP.

**NOTICE**

DHCP addressing is available with Modbus TCP and Ethernet/IP. DHCP addressing is not supported with Profinet.

**12U – Location ID**

<b>Range:</b>	0 - 65535	<b>Default:</b>	0
<b>Description:</b>	Sets the soft starter's unique location ID.		

**20 Advanced****20A – Tracking Gain**

<b>Range:</b>	1% - 200%	<b>Default:</b>	50%
<b>Description:</b>	Fine-tunes the behaviour of the adaptive control algorithm.		

**20B – Pedestal Detect**

<b>Range:</b>	0% - 200%	<b>Default:</b>	80%
<b>Description:</b>	Adjusts the behaviour of the adaptive control algorithm for soft stop.		

**20C – Bypass Contactor Delay**

<b>Range:</b>	50 – 200 milliseconds	<b>Default:</b>	100 milliseconds
<b>Description:</b>	Sets the starter to match the bypass contactor closing/opening time. Set according to the specifications of the bypass contactor used. If this time is too short, the starter will trip.		

**20D – Model Rating**

<b>Range:</b>	Model dependent
<b>Description:</b>	The soft starter's internal model reference, as shown on the silver label on the side of the unit [1].

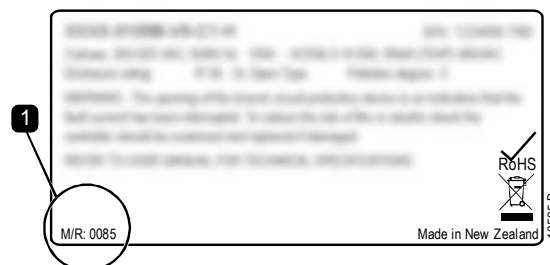
**NOTICE**

This parameter can only be adjusted by authorised servicing agents.

**20E – Screen Timeout**

---

**Options:**      1 minute (default)                      4 minutes  
                      2 minutes                                      5 minutes  
                      3 minutes

**Description:** Sets the timeout for the menu to automatically close if no keypad activity is detected.

**20F – Motor Connection**

---

**Options:**      Auto-detect (default)  
                      In-line  
                      Inside delta

**Description:** Selects whether the soft starter will automatically detect the format of the connection to the motor.

**20G – External Bypass**

---

**Options:**      Disable (default)  
                      Enable

**Description:** If a non-bypassed soft starter is installed with an external bypass contactor, the soft starter's current rating changes. Enable parameter *20G External Bypass* to increase the maximum current rating and adjust the soft starter's thermal model.

**NOTICE**

Parameter *20G External Bypass* only applies to models 0735C~1220C. Changing the setting of this parameter will have no effect on other models.

**20H – Shunt Trip Mode**

---

**Options:**      Disable (default)  
                      Enable

**Description:** Reconfigures the soft starter's main contactor output (33, 34) for use as a shunt trip relay. When the soft starter trips on selected conditions, the relay will activate and the shunt trip will trigger the circuit breaker and disconnect mains voltage from the soft starter.

Use parameters 6C~6T to select which trips will activate the shunt trip relay.

**NOTICE**

If shunt trip operation is enabled, the shunt trip relay will activate for certain non-adjustable trips as well as the selected adjustable trips.

- Current at Stop
- Current Read Err Lx
- EEPROM fail
- Firing Fail Px
- Instantaneous overcurrent
- Internal fault
- Motor connection
- SCR Itsm
- VZC Fail Px

### 30 Smart Card Parameters

Parameter groups 30 and higher are only visible if a smart card is installed and is supported by the soft starter. For parameter details, see the smart card user manual.

### 40 Ground Fault



#### NOTICE

Ground fault protection is only available if a compatible expansion card is installed.

#### 40A – Ground Fault Level

<b>Range:</b>	0 A - 50 A	<b>Default:</b>	0 A
<b>Description:</b>	Sets the trip point for ground fault protection. A setting of 0 disables this protection.		

#### 40B – Ground Fault Delay

<b>Range:</b>	00:00 – 01:30 mm:ss	<b>Default:</b>	1 second
<b>Description:</b>	Slows the soft starter's response to ground fault variation, avoiding trips due to momentary fluctuations.		

If the soft starter detects ground current above 50 A or more than 1.5 times the level set in parameter 40A, it will ignore the delay setting and trip within 1 second.

#### 40C – Ground Fault Trip Active

<b>Options:</b>	Always Active	A trip can occur at any time when the soft starter is receiving power.
	Operating Only (default)	A trip can occur while the soft starter is running, stopping or starting.
	Run Only	A trip can only occur while the soft starter is running.

**Description:** Selects when a ground fault trip can occur.

**40D – Ground Fault Action**

---

<b>Options:</b>	Soft Trip and Log (default)	Warn and Log
	Soft Trip and Reset	Log Only
	Trip Starter	Trip + Shunt Relay
	Trip and Reset	

**Description:** Selects the soft starter's response to the protection event.

**40E – Ground Fault CT Ratio**

---

<b>Options:</b>	1000:1
	2000:1 (default)

**Description:** Set to match the ratio of the ground current measuring CT.

**41 Calibrate 4-20 mA****41A – 4 mA Calibration**

---

<b>Range:</b>	90% - 110%	<b>Default:</b>	100%
---------------	------------	-----------------	------

**Description:** Calibrates the analog output to read exactly 4 mA when the motor is not running.

**41B – 20 mA Calibration**

---

<b>Range:</b>	90% - 110%	<b>Default:</b>	100%
---------------	------------	-----------------	------

**Description:** Calibrates the analog output to read exactly 20 mA when the motor is running at full load current.



# 9 TROUBLESHOOTING

## 9

### Protection responses

When a protection condition is detected, the soft starter will write this to the event log and may also trip or issue a warning. The soft starter's response depends on the Protection Action setting (parameter group 6).

Some protection responses cannot be adjusted by the user. These trips are usually caused by external events (such as phase loss) or by a fault within the soft starter. These trips do not have associated parameters and cannot be set to Warn or Log.

If the soft starter trips you will need to identify and clear the condition that triggered the trip, then reset the soft starter before restarting. To reset the starter, press the [**<**] button on the keypad or activate the Reset remote input.

If the soft starter has issued a warning, the soft starter will reset itself once the cause of the warning has been resolved.

### Trip messages

Display	Possible cause/Suggested solution
2 Phase Damaged SCR	<p>This message is displayed if the soft starter tripped on “Lx-Tx shorted” during the pre-start checks and PowerThrough is enabled. It indicates that the starter now operates in PowerThrough mode (2-phase control only).</p> <p>Check for either a shorted SCR or a short within the bypass contactor.</p> <p>Related parameters: 6S</p>
Battery/clock	<p>A verification error has occurred on the real time clock, or the backup battery voltage is low. If the battery is low and the power is off, date/time settings will be lost. The soft starter will continue to soft start and soft stop correctly. Reprogram the date and time.</p> <p>The battery is not removable. In order to replace the battery, the main control PCB must be replaced.</p> <p>Related parameters: 6T</p>

Display	Possible cause/Suggested solution
Bypass overload	<p>This trip is not adjustable.</p> <p>Bypass overload protection protects the soft starter from severe operating overloads while running. The soft starter will trip if it detects overcurrent at 600% of the contactor rating.</p> <p>Related parameters: None</p>
Current at Stop	<p>The soft starter has detected current at a time when no current is expected (Ready, Not Ready or Tripped states).</p> <ul style="list-style-type: none"> <li>• If the motor is connected inside delta (six-wire connection) and no main contactor is installed, a shorted SCR may be passing current to the motor.</li> </ul> <p>Related parameters: None</p>
Current imbalance	<p>Current imbalance can be caused by problems with the motor, the environment or the installation, such as:</p> <ul style="list-style-type: none"> <li>• An imbalance in the incoming mains voltage</li> <li>• A problem with the motor windings</li> <li>• A light load on the motor</li> <li>• A phase loss on input terminals L1, L2 or L3 during Run mode</li> <li>• An SCR that has failed open circuit. A failed SCR can only be definitely diagnosed by replacing the SCR and checking the starter's performance.</li> </ul> <p>Related parameters: 5A, 5B, 6C</p>
Current Read Err Lx	<p>Where 'X' is 1, 2 or 3.</p> <p>Internal fault (PCB fault). The output from the CT circuit is not close enough to zero when the SCRs are turned off. Contact your local supplier for advice.</p> <p>Related parameters: None</p>
Depth Sensor	<p>The smart card has detected a fault with the depth sensor.</p> <p>Related parameters: 30L, 36C</p>
EEPROM fail	<p>An error occurred loading data from the EEPROM to RAM when the keypad powered up. If the problem persists, contact your local distributor.</p> <p>Related parameters: None</p>

Display	Possible cause/Suggested solution
Excess start time	<p>Excess start time trip can occur in the following conditions:</p> <ul style="list-style-type: none"> <li>parameter 1B <i>Motor Full Load Current</i> is not appropriate for the motor</li> <li>parameter 2D <i>Current Limit</i> has been set too low</li> <li>parameter 2B <i>Start Ramp Time</i> has been set greater than the setting for 5O <i>Excess Start Time</i></li> <li>parameter 2B <i>Start Ramp Time</i> is set too short for a high inertia load when using Adaptive Control</li> </ul> <p>Related parameters: 1B, 2B, 2D, 3D, 3F</p>
Firing Fail Px	<p>Where 'X' is phase 1, 2 or 3.</p> <p>The SCR did not fire as expected. The SCR may be faulty or there may be an internal wiring fault.</p> <p>Related parameters: None</p>
FLC too high	<p>The soft starter can be used on a motor with a higher full load current (FLC) if it is connected inside delta.</p> <ul style="list-style-type: none"> <li>If this trip occurs when the soft starter is installed inside delta, the soft starter may not be correctly detecting the connection. Set parameter 20F <i>Motor Connection</i> to 'Inside Delta'.</li> </ul> <p>Related parameters: 1B, 20F, 20G</p>
Flow Sensor	<p>The smart card has detected a fault with the flow sensor.</p> <p>Related parameters: 30E, 36B</p>
Flow Switch	<p>The flow switch sensor (smart card terminals C23, C24) has closed.</p> <p>Related parameters: 30E, 36H</p>
Frequency	<p>This trip is not adjustable.</p> <p>The mains frequency has gone beyond the specified range. Check for other equipment in the area that could be affecting the mains supply, particularly variable speed drives and switch mode power supplies (SMPS).</p> <p>If the soft starter is connected to a generator set supply, the generator may be too small or could have a speed regulation problem.</p> <p>Related parameters: 6O</p>

Display	Possible cause/Suggested solution
Ground Fault	Test the insulation of the output cables and the motor. Identify and resolve the cause of any ground fault. Related parameters: 40A, 40B, 40C, 40D, 40E
Heatsink overtemperature	<ul style="list-style-type: none"> <li>• Check that bypass contactors are operating.</li> <li>• Check that cooling fans are operating (if fitted).</li> <li>• If mounted in an enclosure, check if ventilation is adequate.</li> <li>• The soft starter must be mounted vertically.</li> </ul> Related parameters: None
High Flow	The flow sensor connected to the smart card has activated high flow protection. Related parameters: 30E, 30G, 30H, 31A, 31C, 31D, 36F
High Pressure	The pressure sensor connected to the smart card has activated high pressure protection. Related parameters: 30A, 30C, 30D, 32A, 32B, 32C, 36D
Input A trip Input B trip	The soft starter's programmable input is set to a trip function and has activated. Resolve the trigger condition. Related parameters: 7A, 7B, 7C, 7D, 7E, 7F, 7G, 7H
Instantaneous overcurrent	This trip is not adjustable. The current on all three phases has exceeded 7.2 times the value of parameter 1B <i>Motor Full Load Current</i> . Causes can include a locked rotor condition or an electrical fault in the motor or cabling. Related parameters: None
Internal fault x	Where 'X' is a number. This trip is not adjustable. The soft starter has tripped on an internal fault. Contact your local supplier with the fault code (X).
Internal fault 88	The soft starter firmware does not match the hardware.
Keypad disconnected	Parameter 1A <i>Command Source</i> is set to Remote Keypad but the soft starter cannot detect a remote keypad. If a remote keypad is installed, check the cable is firmly connected to the soft starter. If no remote keypad is installed, change the setting of parameter 1A. Related parameters: 1A

Display	Possible cause/Suggested solution
L1 phase loss L2 phase loss L3 phase loss	This trip is not adjustable. During pre-start checks the starter has detected a phase loss as indicated. In run state, the starter has detected that the current on the affected phase has dropped below 10% of the programmed motor FLC for more than 1 second, indicating that either the incoming phase or connection to the motor has been lost. Check the supply and the input and output connections at the starter and at the motor end. Related parameters: None
L1-T1 shorted L2-T2 shorted L3-T3 shorted	During pre-start checks the starter has detected a shorted SCR or a short within the bypass contactor as indicated. Consider using PowerThrough to allow operation until the starter can be repaired. Related parameters: 6S
Low Control Volts	The soft starter has detected a drop in the internal control voltage. <ul style="list-style-type: none"> <li>Check the external control supply (A1, A2, A3) and reset the starter.</li> </ul> If the external control supply is stable: <ul style="list-style-type: none"> <li>the 24 V supply on the main control PCB may be faulty; or</li> <li>the bypass driver PCB may be faulty. Contact your local supplier for advice.</li> </ul> This protection is not active in Ready state. Related parameters: None
Low Flow	The flow sensor connected to the smart card has activated low flow protection. Related parameters: 30E, 30G, 30H, 31B, 31C, 31D, 36G
Low Pressure	The pressure sensor connected to the smart card has activated low pressure protection. Related parameters: 30A, 30C, 30D, 32D, 32E, 32F, 36E
Low Water	The depth sensor connected to the smart card has activated depth protection. Related parameters: 30L, 30N, 30O, 34A, 34B, 34C, 36I

Display	Possible cause/Suggested solution
Motor connection Motor Connection T1 Motor Connection T2 Motor Connection T3	<p>This trip is not adjustable.</p> <p>The motor is not connected correctly to the soft starter.</p> <ul style="list-style-type: none"> <li>• Check individual motor connections to the soft starter for power circuit continuity.</li> <li>• Check connections at the motor terminal box.</li> <li>• If the soft starter is connected to a grounded delta mains supply, adjust parameter 20F <i>Motor Connection</i> to match the motor connection configuration.</li> </ul> <p>Related parameters: 20F</p>
Motor overload	<p>The motor has reached its maximum thermal capacity. Overload can be caused by:</p> <ul style="list-style-type: none"> <li>• The soft starter protection settings not matching the motor thermal capacity</li> <li>• Excessive starts per hour or start duration</li> <li>• Excessive current</li> <li>• Damage to the motor windings</li> </ul> <p>Resolve the cause of the overload and allow the motor to cool.</p> <p>Related parameters: 1B, 1D, 1E, 1F, 5O, 6J</p> <p> <b>NOTICE</b></p> <p>Parameters 1D, 1E and 1F determine the trip current for motor overload protection. The default settings of parameters 1D, 1E and 1F provide Motor Overload Protection: Class 10, Trip Current 105% of FLA (full load amperage) or equivalent.</p>
Motor thermistor	<p>The motor thermistor input has been enabled and:</p> <ul style="list-style-type: none"> <li>• The resistance at the thermistor input has exceeded 3.6 kΩ for more than one second.</li> <li>• The motor winding has overheated. Identify the cause of the overheating and allow the motor to cool before restarting.</li> <li>• The motor thermistor input has been opened.</li> </ul> <p>If thermistors have previously been connected to the soft starter but are no longer required, use the Thermistor Reset function to disable the thermistor.</p> <p>Related parameters: 6Q</p>
Network communication	<p>There is a network communication problem, or the network master may have sent a trip command to the starter. Check the network for causes of communication inactivity.</p> <p>Related parameters: 6M</p>

Display	Possible cause/Suggested solution
Not ready	<ul style="list-style-type: none"> <li>The reset input may be active. If the reset input is active, the starter will not operate.</li> <li>The soft starter may be waiting for the restart delay to elapse. The length of the restart delay is controlled by parameter 5P <i>Restart Delay</i>.</li> </ul> <p>Related parameters: 5P</p>
Overcurrent	<p>The current has exceeded the level set in parameter 5E <i>Overcurrent</i> for longer than the time set in parameter 5F <i>Overcurrent Delay</i>. Causes can include a momentary overload condition.</p> <p>Related parameters: 5E, 5F, 6E</p>
Overpower	<p>The motor has experienced a sharp rise in power. Causes can include a momentary overload condition which has exceeded the adjustable delay time.</p> <p>Related parameters: 5M, 5N, 6I</p>
Overvoltage	<p>There has been a voltage surge on the mains. Causes can include problems with a transformer tap regulator or off-loading of a large transformer load.</p> <p>Related parameters: 5I, 5J, 6G</p>
Parameter out of range	<p>This trip is not adjustable.</p> <ul style="list-style-type: none"> <li>A parameter value is outside the valid range. The keypad will indicate the first invalid parameter.</li> <li>An error occurred loading data from the EEPROM to RAM when the keypad powered up.</li> <li>The parameter set or values in the keypad do not match the parameters in the starter.</li> <li>"Load User Set" has been selected but no saved file is available.</li> </ul> <p>Reset the fault. The starter will load the default settings. If the problem persists, contact your local distributor.</p> <p>Related parameters: None</p>
Phase sequence	<p>The phase sequence on the soft starter's input terminals (L1, L2, L3) is not valid.</p> <p>Check the phase sequence on L1, L2, L3 and ensure the setting in parameter 5R is suitable for the installation.</p> <p>Related parameters: 5R, 6P</p>

Display	Possible cause/Suggested solution
Power loss	This trip is not adjustable. The starter is not receiving mains supply on one or more phases. Check that the main contactor closes when a start command is given, and remains closed until the end of a soft stop. Check the fuses. If testing the soft starter with a small motor, it must draw at least 10% of the starter's programmed FLC setting on each phase. If shunt relay mode is enabled (parameter 20H <i>Shunt Trip Mode</i> ), certain trips may cause the shunt relay to open the circuit breaker. Related parameters: None
Pressure Sensor	The smart card has detected a fault with the pressure sensor. Related parameters: 30A, 36A
Rating Capacity	The soft starter is operating beyond its safe capacity. Allow the starter to cool. Related parameters: None
RTD Circuit	The smart card has detected a fault with the RTD sensor, or the RTD has activated temperature protection. Related parameters: 35B, 36J
SCR Itsm	The SCR current surge rating has been exceeded. Related parameters: None
SCR overtemperature	The temperature of the SCRs, calculated by the thermal model, is too high to allow further operation. Wait for the starter to cool. Related parameters: None
Starter communication	There is a problem with the connection between the soft starter and the optional expansion card. Remove and reinstall the card. If the problem persists, contact your local distributor. Related parameters: None
Starts per hour	The soft starter has already attempted the maximum number of starts in the last 60 minutes. Wait before attempting another start. To determine when the waiting period will end, review the log. Related parameters: 5Q
Thermistor circuit	The thermistor input has been enabled and: <ul style="list-style-type: none"> <li>• The resistance at the input has fallen below 20 <math>\Omega</math> (the cold resistance of most thermistors will be over this value) or</li> <li>• A short circuit has occurred. Check and resolve this condition.</li> </ul> Related parameters: None
Time-overcurrent	The soft starter is internally bypassed and has drawn high current during running. (The 10A protection curve trip has been reached or the motor current has risen to 600% of the motor FLC setting.) Related parameters: None



Display	Possible cause/Suggested solution
Undercurrent	The motor has experienced a sharp drop in current, caused by loss of load. Causes can include broken components (shafts, belts or couplings), or a pump running dry. Related parameters: 5C, 5D, 6D
Underpower	The motor has experienced a sharp drop in power, caused by loss of load. Causes can include broken components (shafts, belts or couplings), or a pump running dry. Related parameters: 5K, 5L, 6H
Undervoltage	Mains voltage has fallen below the level selected. Causes can include an undersized supply or adding a large load to the system. Related parameters: 5G, 5H, 6F
Unsupported option	The selected function is not available (eg jog is not supported in inside delta configuration). Related parameters: None
VZC Fail Px	Where 'X' is 1, 2 or 3. Internal fault (PCB fault). Contact your local supplier for advice. Related parameters: None
Zero Speed Detect	The zero speed input has not closed within the expected duration of a soft stop. <ul style="list-style-type: none"> <li>• Check the zero speed sensor is operating correctly.</li> <li>• Check that parameters 2Q <i>Brake Current Limit</i> and 5O <i>Excess Start Time</i> are appropriate for the application.</li> </ul> Related parameters: 2Q, 3S, 5O



EN

## General faults

This table describes situations where the soft starter does not operate as expected but does not trip or give a warning.

Symptom	Probable Cause
Starter "Not Ready"	<ul style="list-style-type: none"> <li>• The reset input may be active. If the reset input is active, the starter will not operate.</li> </ul>
"Simul" on display	<ul style="list-style-type: none"> <li>• The starter is running simulation software. This software is intended for demonstration purposes only and is not suitable for controlling a motor. Contact your local supplier for advice.</li> </ul>
The soft starter does not respond to the <b>START</b> or <b>RESET</b> button on the remote keypad.	<ul style="list-style-type: none"> <li>• The soft starter will only accept commands from the keypad if parameter 1A <i>Command Source</i> is set to Remote Keypad. Check that the Local LED on the starter is on.</li> </ul>

Symptom	Probable Cause
The soft starter does not respond to commands from the control inputs.	<ul style="list-style-type: none"> <li>• The soft starter will only accept commands from the inputs if parameter 1A <i>Command Source</i> is set to Digital Input. Check the setting of 1A.</li> <li>• The control wiring may be incorrect. Check that the remote start, stop and reset inputs are configured correctly (see on <i>Start/Stop</i> page 30 for details).</li> <li>• The signals to the remote inputs may be incorrect. Test the signalling by activating each input signal in turn.</li> </ul>
The soft starter does not respond to a start command from either the keypad or the digital inputs.	<ul style="list-style-type: none"> <li>• The soft starter may be waiting for the restart delay to elapse. The length of the restart delay is controlled by parameter 5P <i>Restart Delay</i>.</li> <li>• The motor may be too hot to permit a start. The soft starter will only permit a start when it calculates that the motor has sufficient thermal capacity to complete the start successfully. Wait for the motor to cool before attempting another start.</li> <li>• The reset input may be active. If the reset input is active, the starter will not operate.</li> <li>• The soft starter may be waiting for control signals via the communications network (parameter 1A <i>Command Source</i> = Network).</li> <li>• The soft starter may be waiting for a scheduled auto-start (parameter 1A <i>Command Source</i> = Clock).</li> </ul>
Erratic and noisy motor operation.	<ul style="list-style-type: none"> <li>• If the soft starter is connected to the motor using inside delta configuration, the soft starter may not be correctly detecting the connection. Contact your local supplier for advice.</li> </ul>
Remote keypad shows message "awaiting data"	The keypad is not receiving data from the control PCB. Check the cable connection.
The soft starter does not control the motor correctly during starting.	<ul style="list-style-type: none"> <li>• Start performance may be unstable when using a low <i>Motor Full Load Current</i> setting (parameter 1B).</li> <li>• Power factor correction (PFC) capacitors must be installed on the supply side of the soft starter and must be disconnected during starting and stopping. To use the soft starter to control power factor correction, connect the PFC contactor to a programmable relay set to Run.</li> <li>• High levels of harmonics on the mains supply can affect soft starter performance. If variable speed drives are installed nearby, check they are properly grounded and filtered.</li> </ul>

Symptom	Probable Cause
Motor does not reach full speed.	<ul style="list-style-type: none"> <li>If the start current is too low, the motor will not produce enough torque to accelerate to full speed. The soft starter may trip on excess start time.</li> </ul> <p> <b>NOTICE</b> Make sure the motor starting parameters are appropriate for the application and that you are using the intended motor starting profile. If a programmable input is set to Motor Set Select, check that the corresponding input is in the expected state.</p> <ul style="list-style-type: none"> <li>The load may be jammed. Check the load for severe overloading or a locked rotor situation.</li> </ul>
Soft stop ends too quickly.	<ul style="list-style-type: none"> <li>The soft stop settings may not be appropriate for the motor and load. Review the soft stop settings.</li> <li>If the motor is very lightly loaded, soft stop will have limited effect.</li> </ul>
After selecting Adaptive Control the motor used an ordinary start and/or the second start was different to the first.	<ul style="list-style-type: none"> <li>The first Adaptive Control start is actually 'Constant Current' so that the starter can learn from the motor characteristics. Subsequent starts use Adaptive Control.</li> </ul>
PowerThrough does not operate when selected.	<ul style="list-style-type: none"> <li>The starter will trip on Lx-Tx Shorted on the first start attempt after control power is applied. PowerThrough will not operate if control power is cycled between starts.</li> </ul>
Parameter settings cannot be stored.	<ul style="list-style-type: none"> <li>Make sure you are saving the new value by pressing the button  after adjusting a parameter setting. If you press [<b>&lt;</b>], the change will not be saved. The soft starter does not display a confirmation.</li> <li>Check that the adjustment lock (parameter 10G) is set to Read &amp; Write. If the adjustment lock is set to Read Only, settings can be viewed but not changed.</li> </ul>
USB Full	<ul style="list-style-type: none"> <li>The USB drive may not have enough free space available for the selected function.</li> <li>The file system on the USB drive may not be compatible with the soft starter. The soft starter supports FAT32 file systems. The soft starter's USB functions are not compatible with NTFS file systems.</li> </ul>
USB Missing	A USB function has been selected in the menu, but the product cannot detect a USB drive. Check that the USB drive has been inserted in the port.

Symptom	Probable Cause
File Missing	A USB function has been selected in the menu, but the required file cannot be found. Save/Load Master Parameters uses a file called Master_Parameters.par, at the top level of the USB drive. For these functions to work correctly, do not move or rename this file.
File Not Valid	A USB function has been selected in the menu, but the file is not valid.
File Empty	A USB function has been selected in the menu and the file has been found, but does not contain the expected content.
Rating Not Valid	The value of parameter 20D <i>Model Rating</i> is incorrect. Parameter 20D is not user-adjustable. Contact your local supplier for advice.



## Product Compatibility

This user manual is suitable for use with Power Electronics V6 soft starters version 7 (user interface software 3.0 and motor control code 4.x).

The software versions screen reports the version of each software component in the starter.

For other versions, please contact your local supplier.

## Certification

CE ..... EN 60947-4-2

RCM ..... IEC 60947-4-2

RoHS ..... 

UK CA ..... 

WEEE ..... 2002/96/EC



**24H TECHNICAL ASSISTANCE 365 DAYS A YEAR**

FIND YOUR NEAREST DELEGATION  
**[POWER-ELECTRONICS.COM/CONTACT/](http://POWER-ELECTRONICS.COM/CONTACT/)**

**@ in   **